

SATURN - BOXER

MOTORIDUTTORI PER CANCELLI SCORREVOLI
MOTOR REDUCERS FOR SLIDING GATES
MOTEURS POUR PORTAILS COULISSANTS



SEA S.p.A.

Zona Industriale Sant'Atto - 64100 - Teramo - ITALY
Telephone: + 39 0 861 588341 - Fax: + 39 0 861 588344

www.seateam.com

GENERAL FEATURES

SATURN and the **BOXER** are gearmotors designed for the automation of sliding gates.

The operators are available in **version with grease** lubrication or in **oil bath version**.

The irreversibility of the gearmotors allows a perfect and safe closing of the gate avoiding the installation of the electric lock and, in the event of a power failure, the release device placed on the front part allows the manual opening and closing. **The operators are equipped with an electronic clutch device (some versions of adjustable mechanical clutch)**, which guarantees an adjustment of the thrust on the gate. In addition, **the electronic inversion system (optional) through Encoder**, makes the **SATURN** and **BOXER** gearmotors safe and reliable operators, allowing in a simple way to comply with the regulations in force in the countries where the product is installed.

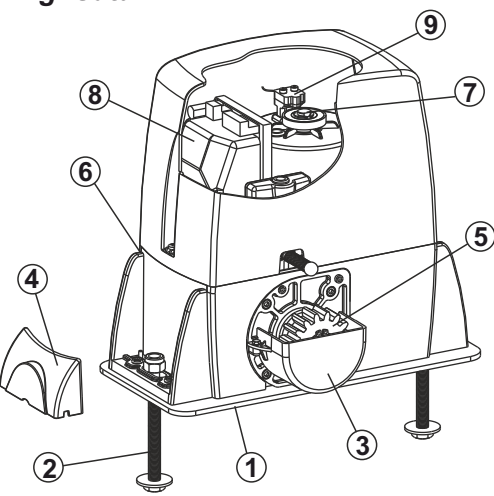
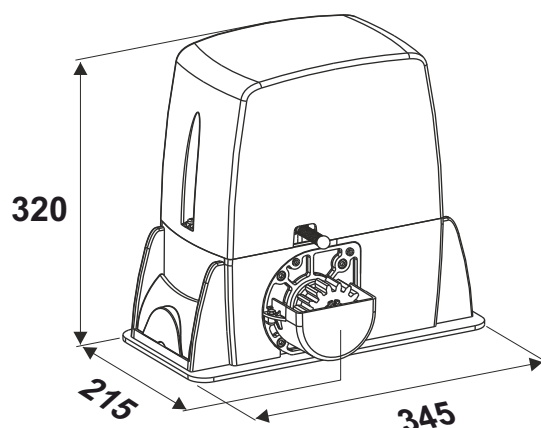
COMPONENTS	DIMENSIONS (in mm)
<p><i>E.g. Saturn</i></p>  <p>Fig. 1</p>	 <p>Fig. 2</p>

APPLICATION CHART

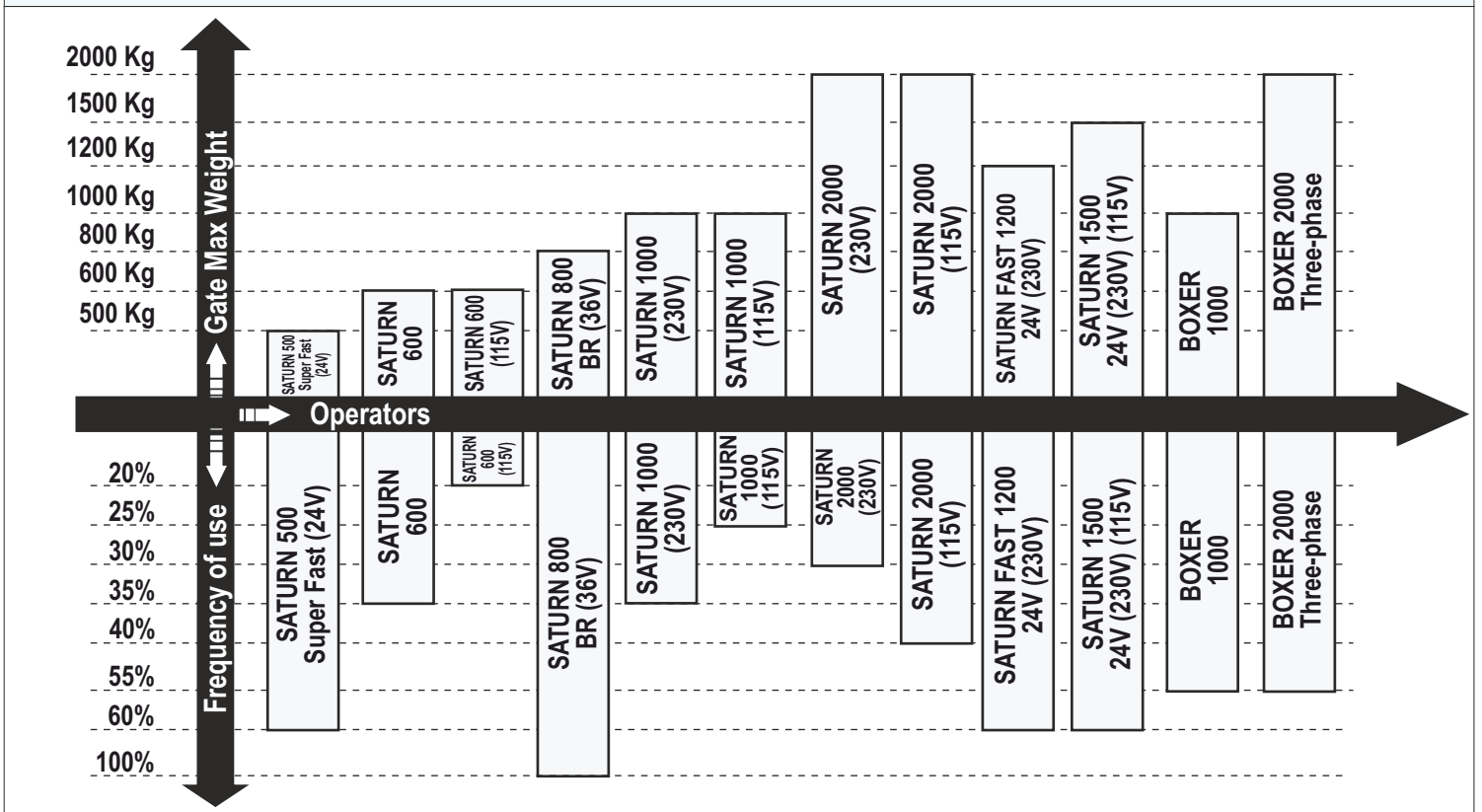

TECHNICAL DATA	SATURN 600 - 1000 - 2000 (230V)			SATURN 600 - 1000 - 2000 (115V)		
	SATURN 600	SATURN 1000	SATURN 2000	SATURN 600	SATURN 1000	SATURN 2000
Power supply	230V~ ± 5% - 50/60 Hz			115V~ ± 5% - 50/60 Hz		
Power	320W	350W	600W	400W	700W	
Absorbed current	1,5 A	1,7 A	1,8 A	3,2 A	5,0 A	
Motor capacitor	16 µF	20 µF	25 µF	50 µF	70 µF	
Working frequency	55%			20%	25%	40%
Working Temperature	-20°C ↯ +55°C ↯			-20°C ↯ +55°C ↯		
Thermoprotection	150°C			150°C		
Weight	12,5 Kg	13 Kg	14,5 Kg	12 Kg	13 Kg	14,5 Kg
Anticrushing clutch	Electronic/Mechanical			Electronic		Elect./Mech.
Protection class	IP55			IP55		
Pinion Z16 (Z20) speed	0,15 (0,18) m/s			0,15 (0,18) m/s		
Maximum torque	30 Nm	55 Nm	70 Nm	50 Nm	55 Nm	70 Nm
Gate maximum weight	600 Kg	1000 Kg	2000 Kg	600 Kg	1000 Kg	2000 Kg
Gate maximum length	6 m	10 m		6 m	10 m	
Mechanical clutch	If foreseen by the model			No		Yes
Limit switch	Inductive or Mechanical or Magnetic			Inductive or Mechanical		

TECHNICAL DATA	SATURN 800 BR 36V BRUSHLESS	SATURN 500 SUPER FAST 24V (230V)	SATURN 1200 FAST 24V (230V)	SATURN 1500 24V (230V)	SATURN 1500 24V (115V)
Power supply	230V~ ± 5% - 50/60 Hz				115V~ ± 5% - 50/60 Hz
Motor	36V ≡	24V ≡			
Absorbed power	330 W	100W			
Working frequency	100%	60%			
Working Temperature	-20°C ↯ +55°C ↯				
Weight	14 Kg	14,3 Kg			
Anticrushing clutch	Electronic				
Protection class	Ip55				
Pinion speed	0,28 m/s Max (Z16)	0,40 m/s Max (Z20)	0,32 m/s Max (Z16)	0,25 m/s Max (Z13)	
Maximum torque	45 Nm	45 Nm	60 Nm	65 Nm	
Gate max. weight	800 Kg	500 Kg	1200 Kg	1500 Kg	
Gate maximum length	10 m				
Limit switch	Inductive or Mechanical				

TECHNICAL DATA	BOXER 1000	BOXER 2000	BOXER 2000 Three-phase	NOTES	
Power supply	230V~ ± 5% - 50/60 Hz		230V/380V (±5%) 50/60Hz	The indicated frequency of use is valid only for the first operating hour and at a 20°C room temperature	
Power	350W	700W	400W		
Absorbed current	1,7 A	1,8 A	1,0 A		
Motor capacitor	20 µF	25µF	-	In the versions SATURN and BOXER with INVERTER, the max speed allowed by the different pinions is shown in the following table:	
Working frequency	70%		50%		
Working Temperature	-20°C ↯ +55°C ↯			SATURN 1000/2000 INVERTER BOXER 1000/2000 INVERTER	
Thermoprotection	150°C		-		
Weight	14 Kg	15 Kg		PINION Z13	Max. 0,21 m/s
Anticrushing clutch	Electronic/Mechanical		Mechanical	PINION Z16	Max. 0,266 m/s
Protection class	IP55			PINION Z20	Max. 0,33 m/s
Pinion Z16 (Z20) speed	0,15 (0,18) m/s				
Maximum torque	55 Nm	70 Nm			
Gate maximum weight	1000 Kg	2000 Kg			
Gate maximum length	10 m				
Mechanical clutch	If foreseen by the model				
Limit switch	Inductive or Mechanical				

1 - GATE ARRANGEMENTS

Before the installation, check that all gate parts (fixed and mobile) have a resistant and non-deformable structure; also make the following checks:

- a) The gate must be rigid and compact;
- b) The lower gate slideway must be perfectly straight, horizontal and without any obstacles which could obstruct the gate sliding;
- c) The lower sliding wheels must be equipped with greasable or watertightened bearings;
- d) The upper slideway must be perfectly straight and placed so that the gate could be in vertical position;
- e) *The mechanical stops of the gate must always be installed in order to avoid any possible derailment*

2 - INSTALLATION OF THE FOUNDATION PLATE

To install the foundation plate it is necessary to:

2.1. Prepare a concrete basement according to the dimensions shown in Fig. 3; The foundation plate and the anchor bolts must be concreted inside the basement

NOTE: *IF ALLOWED BY THE GATE STRUCTURE, IT IS RECOMMENDED TO LIFT THE FOUNDATION PLATE OF ABOUT 50mm FROM THE GROUND, IN ORDER TO AVOID EVENTUAL WATER STAGNATION.*

2.2. Before cementing the plate insert a flexible plastic pipe of at least 30 mm in diameter into the special hole of the plate

2.3. Before concreting the plate, make sure that it is perfectly levelled and that the distance of 58-67 mm as shown in Fig. 4 is respected

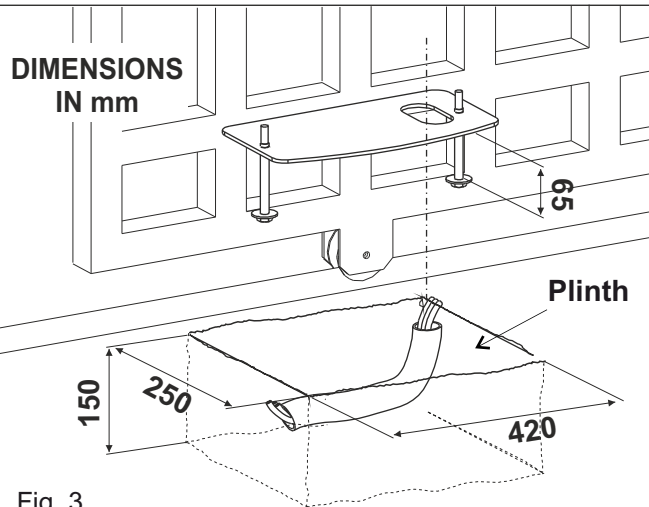

Fig. 3

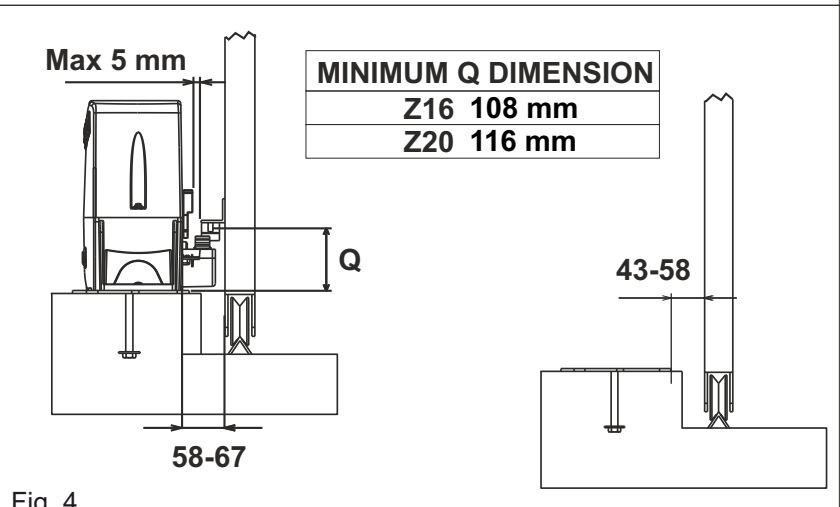

Fig. 4

3 - CABLES PASSAGE ARRANGEMENT

Saturn and Boxer are provided with two different holes for electric cables passage.

It's very important to make the low - tension 230V~ cables pass through one hole and the very low safety tension 24V cables through the other one (Fig. 5)

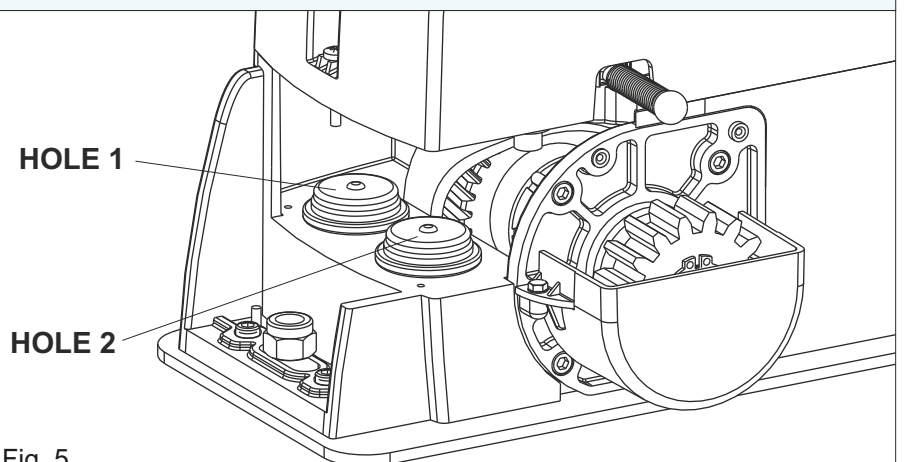

Fig. 5

4 - INSTALLATION OF THE OPERATOR

4.1. Insert the 4 grub screws into the special holes, in order to adjust the gearmotor height on the plate (Fig. 6) **At the end of installation check if the 4 grub screws are well gripped on the foundation plate**

4.2. Fix the gear motor to the foundation plate using the 2 included nuts, adjusting the side position (Fig. 7) so to respect the shown quota in Fig. 4



ATTENTION! REMOVE THE RED TRANSPORT OIL CAP AND REPLACE IT WITH THE BLACK ONE SUPPLIED, PROVIDED WITH AIRHOLE

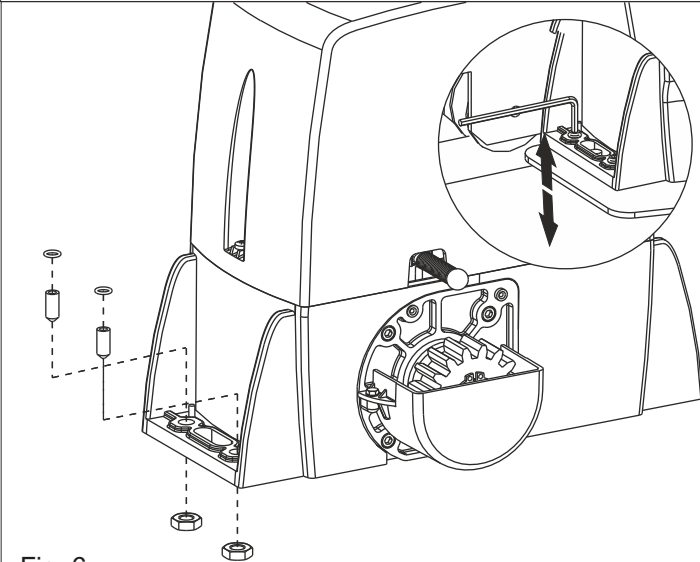

Fig. 6

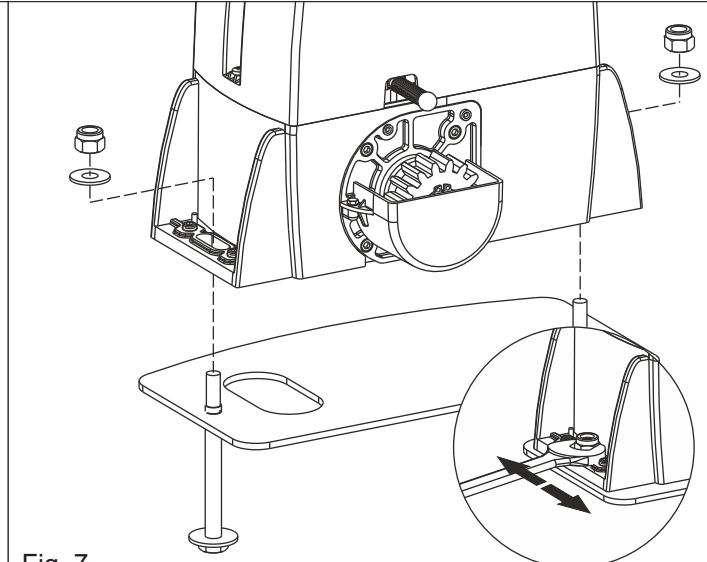

Fig. 7

5 - GEAR RACK MOUNTING

5.1. Release the operator and open the leaf completely;

5.2. Fix on each gear rack element the support pawls with the appropriate lock screws, making sure to put them in the upper part of the hole (Fig. 8) ;

5.3. Lean the gear rack element on the toothed pinion of the operator in parallel to the ground slideway of the gate, as shown in Fig. 9 and electrically weld the central pawl **B** to the gate structure (Fig. 10). Manually move the gate until pawl **C** is placed in front of the pinion and fix it through electric welding. Repeat the same procedure for pawl **A** after having placed it in front of the pinion;

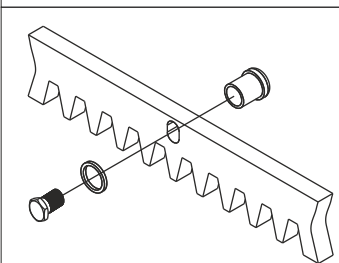

Fig. 8

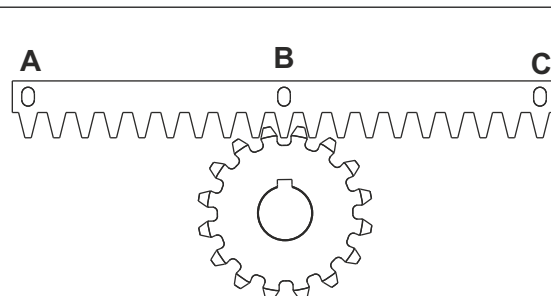

Fig. 9

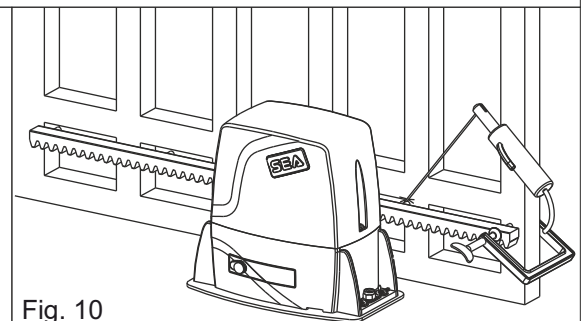

Fig. 10

5.4. Make sure that all the gear rack elements are perfectly aligned and correctly placed (the teeth must be in phase). It is suggested to oppose an element to two aligned elements as shown in Fig. 11;

5.5. Repeat the above described operation for all the remaining gear rack elements which have to be installed;

5.6. go avoid that the gate weights down the pinion (Fig.12) lift up the whole rack about 1,5 mm.

Caution! Keep a gap of about 0,5 mm between pinion tooth and gear rack tooth;

5.7. Make sure that the gear rack works at the midpoint of the pinion along all the rack elements, if necessary, adjust the length of the spacers

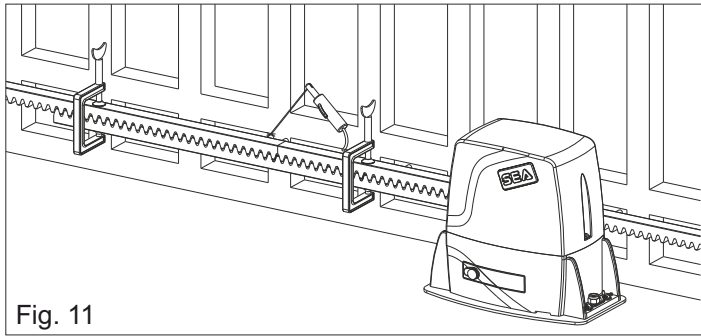

Fig. 11

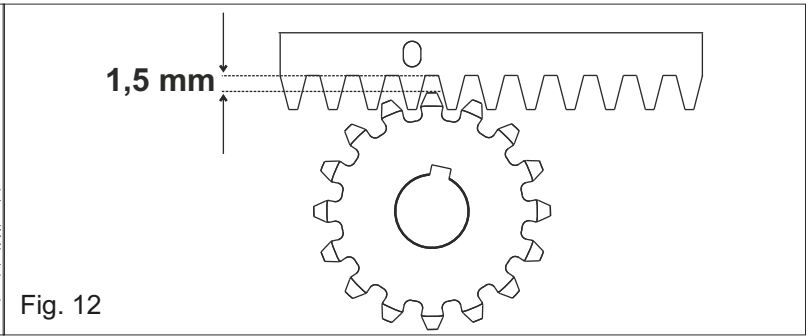

Fig. 12

6 - LIMIT SWITCH ADJUSTMENT

6.1. IN OPENING

- Fully open the gate
- **MECHANICAL STOP:** place the plate (Fig. 13) on the rack according to the desired gate stop position; fix the plate on the rack using the screws.
- **INDUCTIVE LIMIT SWITCH:** place the plate (Fig. 14) on the rack according to the desired gate stop position; fix the plate on the rack using the screws. Bring the inductive limit switch opening plate (indicated by an arrow on the limit switch) in correspondence with point «X» of the plate on the rack (50 mm from the folded side of the plate - Fig. 15).

6.2. IN CLOSING

- Fully close the gate
- **MECHANICAL STOP:** place the plate (Fig. 13) on the rack according to the desired gate stop position; fix the plate on the rack using the screws.
- **INDUCTIVE LIMIT SWITCH:** place the plate (Fig. 14) on the rack according to the desired gate stop position; fix the plate on the rack using the screws. Bring the inductive limit switch closing plate (indicated by an arrow on the limit switch) in correspondence with point «X» of the plate on the rack (50 mm from the folded side of the plate - Fig. 15).

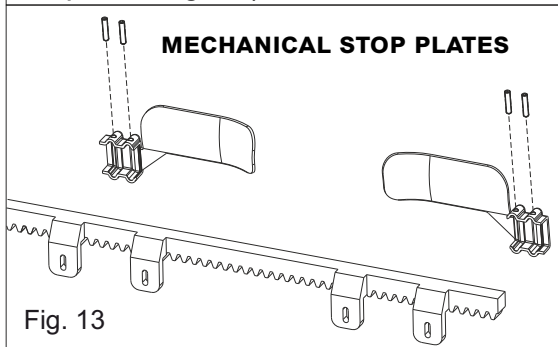

Fig. 13

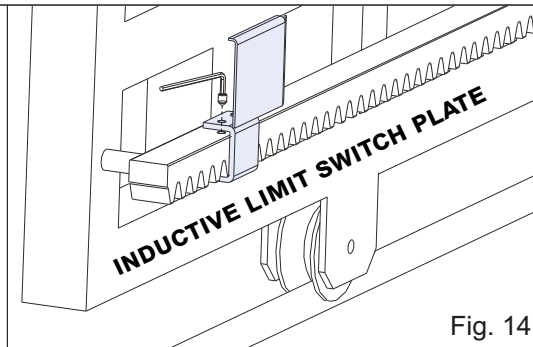

Fig. 14

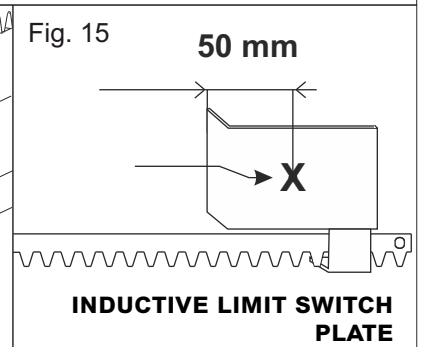

Fig. 15

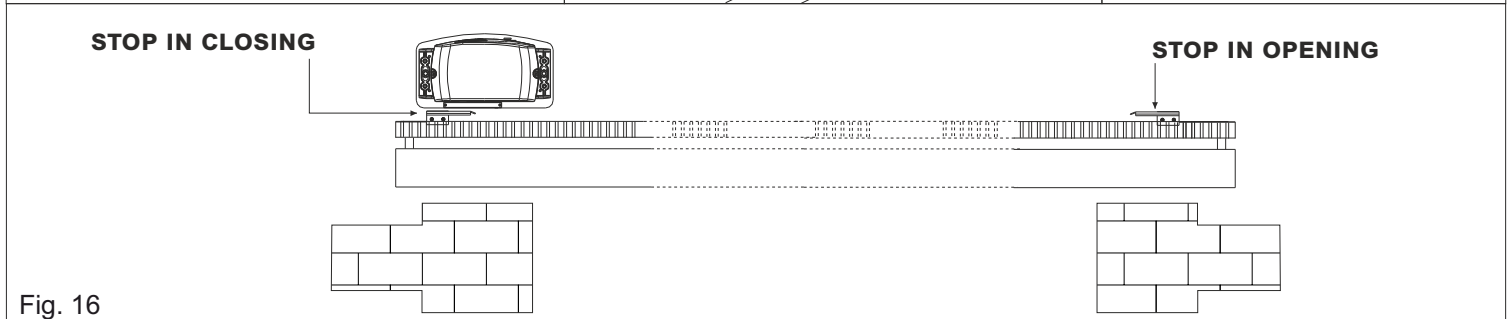

Fig. 16

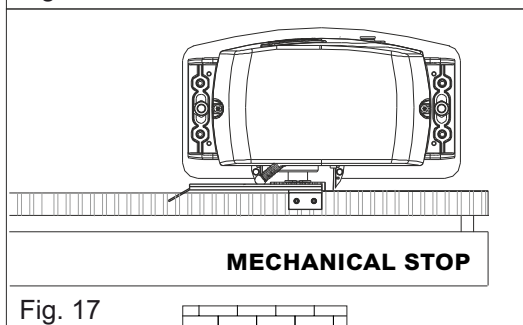

Fig. 17

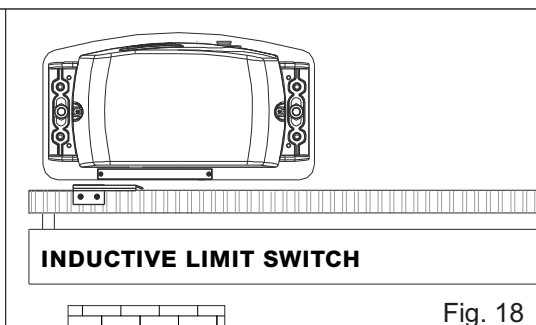

Fig. 18

NOTE

FOR FURTHER DETAILS ON THE ADJUSTMENT OF THE INDUCTIVE LIMIT SWITCH, REFER TO THE PROGRAMMING MANUAL OF THE ELECTRONIC CONTROL BOARD

7 - MAGNETIC LIMIT SWITCH ADJUSTMENT

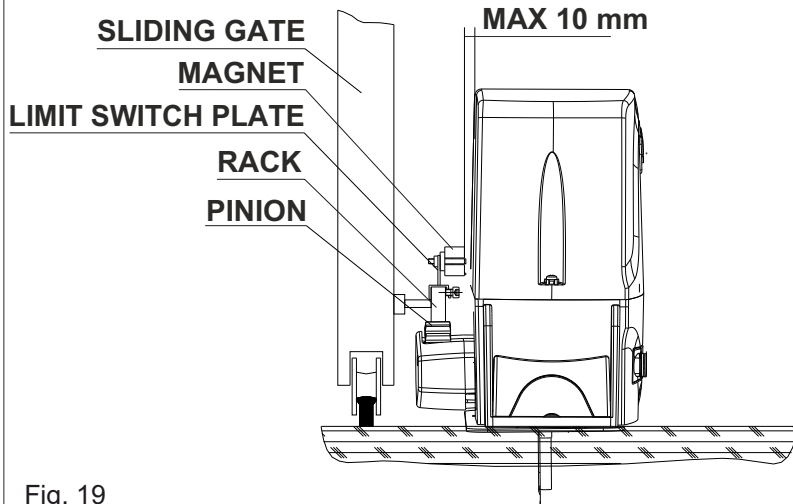

Fig. 19

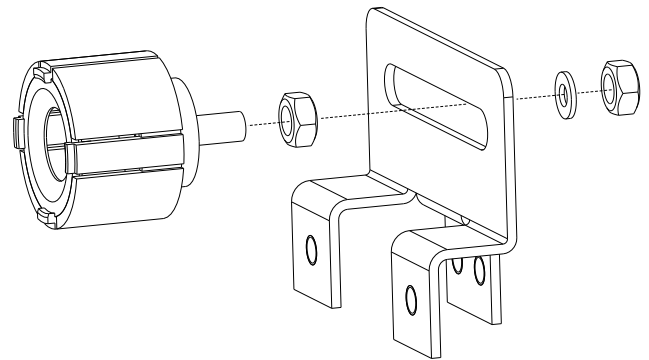

Fig. 20

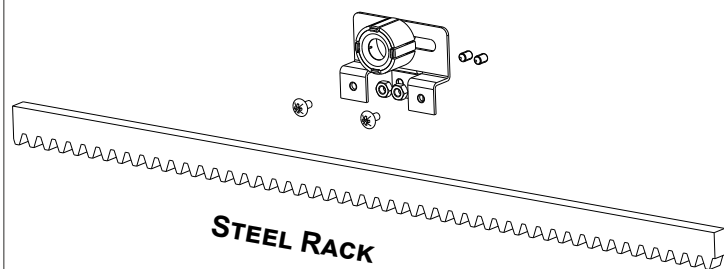

Fig. 21

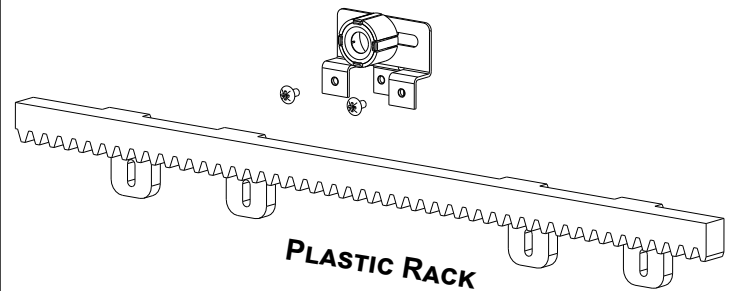

Fig. 22

8 - GROUNDING

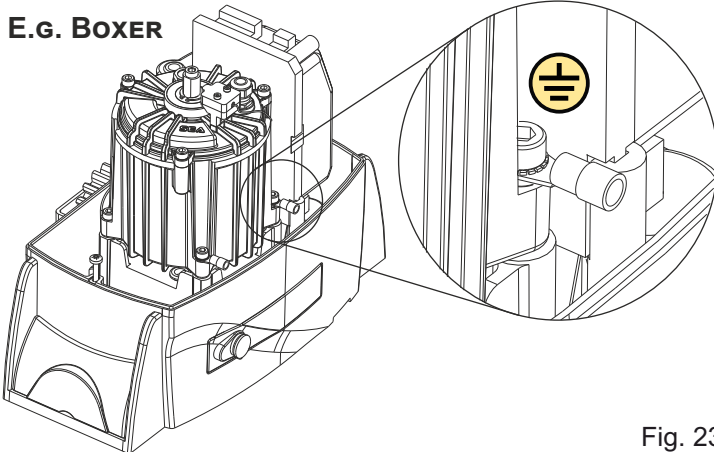

Fig. 23

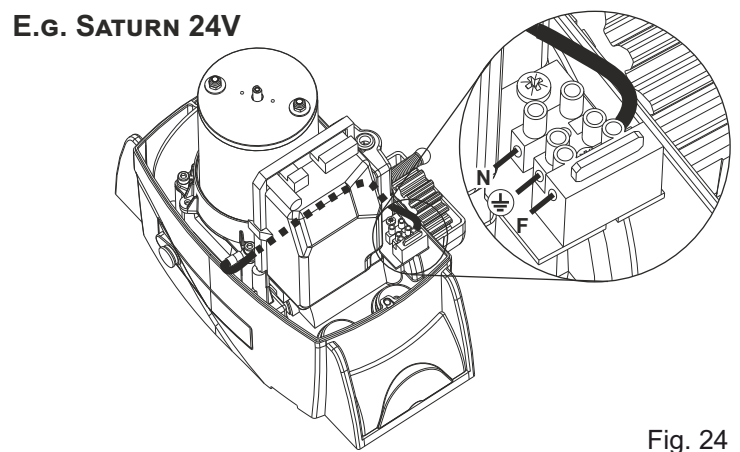

Fig. 24

9 - CLUTCH ADJUSTMENT (OPTIONAL)

9.1. Switch off the electric power supply

9.2. In order to adjust the clutch, act on the grub screw "A" (Fig. 25) as follows:

- **Turning clockwise** = less clutch sensibility - more thrust force
- **Turning counter-clockwise** = more clutch sensibility - less thrust force

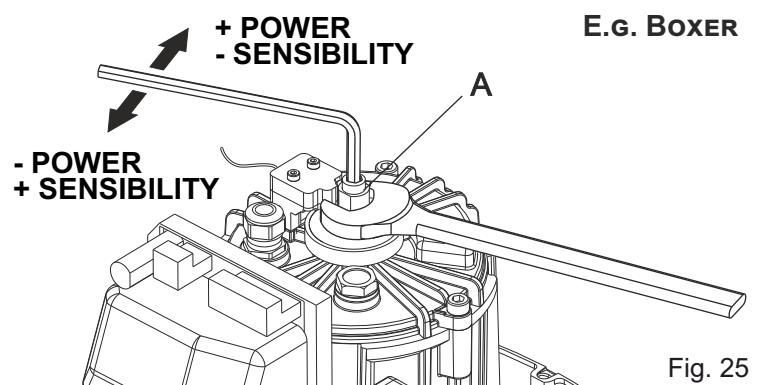

Fig. 25

10 - SCREW-COVER MOUNTING

At the end of the mechanical installation and after having executed all the required adjustments, mount the two screw covers on the operator as shown in Fig. 26

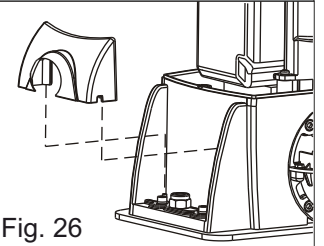

Fig. 26

11 - ELECTRIC WIRINGS

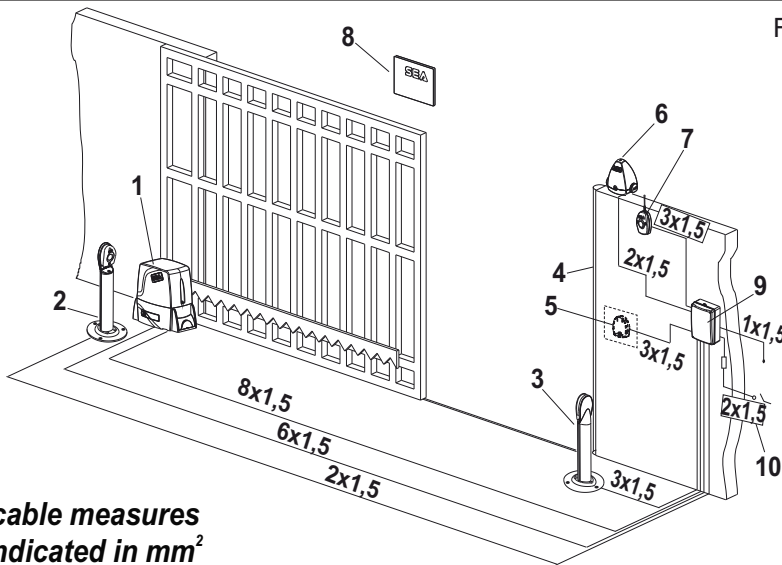

Fig. 27

- 1) Saturn - Boxer
- 2) Left photocell
- 3) Right photocell
- 4) Mechanical safety edge
- 5) Key button
- 6) Flash lamp
- 7) Receiver
- 8) Warning notice
- 9) Junction box
- 10) Differential 16A - 30mA

E.g. 230V version with integrated electronic control unit

The cable measures are indicated in mm²

PART FOR BOTH INSTALLER AND END-USER



CAUTION! SWITCH-OFF THE POWER SUPPLY BEFORE TO LOCK OR UNLOCK THE OPERATOR!
IN CASE OF MALFUNCTION, ALWAYS CONTACT AN AUTHORIZED INSTALLER!

12 - RELEASE SYSTEM FOR SATURN AND BOXER

12.1. To release the operator:

- Open the lock cover, insert the key and rotate 90° clockwise (Fig. 28)
- Pull the release lever until it stops, about 90° approximately (Fig. 29)

Note: when pull the release lever, the control unit receives a safety stop impulse thanks to a micro-switch inside the operator (anyway it is highly recommended to switch OFF the power supply before)

12.2. To lock the operator:

- Push the release lever to complete closing.
- Rotate the key counter-clockwise and extract it.
- Close the protective lock cover.

Once the lock has been restored the electronic control unit reactivates if the power supply was ON

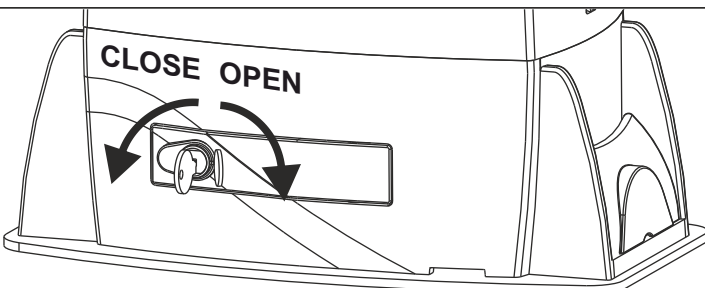

Fig. 28

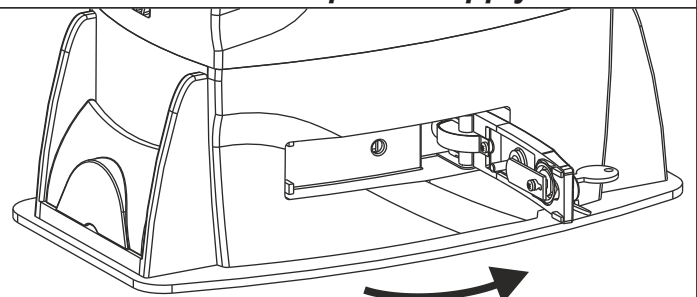

Fig. 29

PART FOR BOTH INSTALLER AND END-USER

PERIODIC MAINTENANCE

Check the oil level (for operators in oil-bath) by the use of the oil level rod	Annual
Change oil (for operators in oil-bath)	4 years
Check the release good functioning	Annual
Check the clutch functionality (for operators with clutch)	Annual
Check the distance between pinion and gear rack (1.5 mm)	Annual
Check the condition of the pinion and the gear rack (if overused or damaged)	Annual
Check the fixing screws	Annual
Check the connection cables integrity	Annual
Check the limit switch functionality and status in opening and closing; also check the condition of the stop plates	Annual



ALL OPERATIONS MUST BE CARRIED OUT EXCLUSIVELY BY AN AUTHORIZED INSTALLER

NOTICE

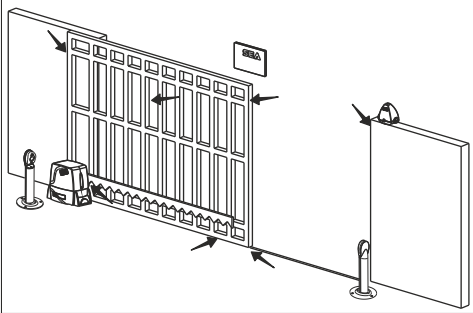

RISK EXAMINATION: The points pointed by arrows are potentially dangerous. The installer must take a thorough risk examination to prevent crushing, conveying, cutting, grappling, trapping so as to guarantee a safe installation for people, things and animals (Re. Laws in force in the Country where installation has been made). As for misunderstandings that may arise refer to your area distributor or call our help desk. These instructions are part of the device and must be kept in a well known place. The installer shall follow the provided instructions thoroughly. SEA products must only be used to automate doors, gates and wings. Any initiative taken without SEA explicit authorization will preserve the manufacturer from whatsoever responsibility. The installer shall provide warning notices on not assessable further

risks. SEA in its relentless aim to improve the products, is allowed to make whatsoever adjustment without giving notice. This doesn't oblige SEA to upgrade the past production. SEA can not be deemed responsible for any damage or accident caused by product breaking, being damages or accidents due to a failure to comply with the instructions herein. The guarantee will be void and the manufacturer responsibility will be nullified if SEA original spare parts are not being used. The electrical installation shall be carried out by a professional technician who will release documentation as requested by the laws in force. Packaging materials such as plastic bags, foam polystyrene, nails etc must be kept out of children's reach as dangers may arise.

INITIAL TEST AND STARTING OF THE AUTOMATION: After having completed the necessary operations for a correct installation of the product and after having evaluated all the risks which could arise in any installation, **it is necessary to test the automation to guarantee the maximum security and, in particular, to guarantee that the laws in force are fully respected.** The first Start must be executed according to the rule **EN 12445** which establishes the methods of tests for checking the gate automation respecting the limits established by the rule **EN 12453**

SAFETY PRECAUTIONS: All electrical work should comply with the current regulations. A 16A / 0,030 differential switch must be used. Separate the source cables (operators, power supply) and command cables (photocells, push-buttons, etc). Be sure the entire system is properly earth bonded. Always run cables in separate ducts to prevent interferences

INTENDED USE: The operator has been designed to be used for the automation of sliding gates only

SPARE PARTS: Send request for spare parts to: **SEA S.p.A. - Teramo - ITALY - www.seateam.com**

SAFETY AND ENVIRONMENTAL COMPATIBILITY: Don't waste product packing materials and/or circuits

STORAGE: T = -30°C/+60°C ; Humidity = min. 5% / max. 90% (without condensation); Materials must be properly packaged, handled with care and with appropriate vehicles

WARRANTY LIMITS - see the sales conditions

MAINTENANCE AND DECOMMISSION: must only be carried out by specialised and authorised personnel

THE MANUFACTURER CAN NOT BE DEEMED RESPONSIBLE FOR ANY DAMAGE OR INJURY CAUSED BY IMPROPER USE OF THIS PRODUCT

SEA S.p.A. reserves the right to make any required modification or change to the products and/or to this manual without any advanced notice obligation.

AVVERTENZE GENERALI PER INSTALLATORE E UTENTE

1. Leggere attentamente le Istruzioni di Montaggio e le Avvertenze Generali prima di iniziare l'installazione del prodotto. Conservare la documentazione per consultazioni future
2. Non disperdere nell'ambiente i materiali di imballaggio del prodotto e/o circuiti
3. Questo prodotto è stato progettato e costruito esclusivamente per l'utilizzo indicato in questa documentazione. Qualsiasi altro utilizzo non espressamente indicato potrebbe pregiudicare l'integrità del prodotto o rappresentare fonte di pericolo. L'uso improprio è anche causa di cessazione della garanzia. La SEAS.p.A. declina qualsiasi responsabilità derivata dall'uso improprio o diverso da quello per cui l'automatismo è destinato
4. I prodotti SEA sono conformi alle Direttive: Macchine (2006/42/CE e successive modifiche), Bassa Tensione (2006/95/CE e successive modifiche), Compatibilità Elettromagnetica (2004/108/CE e successive modifiche). L'installazione deve essere effettuata nell'osservanza delle norme EN 12453 e EN 12445
5. Non installare l'apparecchio in atmosfera esplosiva
6. SEAS.p.A. non è responsabile dell'inosservanza della Buona Tecnica nella costruzione delle chiusure da motorizzare, nonché delle deformazioni che dovessero verificarsi durante l'uso
7. Prima di effettuare qualsiasi intervento sull'impianto, togliere l'alimentazione elettrica e scollegare le batterie. Verificare che l'impianto di terra sia realizzato a regola d'arte e collegarvi le parti metalliche della chiusura.
8. Per ogni impianto SEAS.p.A. consiglia l'utilizzo di almeno una segnalazione luminosa nonché di un cartello di segnalazione fissato adeguatamente sulla struttura dell'infisso
9. SEAS.p.A. declina ogni responsabilità ai fini della sicurezza e del buon funzionamento della automazione, in caso vengano utilizzati componenti di altri produttori
10. Per la manutenzione utilizzare esclusivamente parti originali SEA
11. Non eseguire alcuna modifica sui componenti dell'automazione
12. L'installatore deve fornire tutte le informazioni relative al funzionamento manuale del sistema in caso di emergenza e consegnare all'Utente utilizzatore dell'impianto il libretto d'avvertenze allegato al prodotto
13. Non permettere ai bambini o persone di sostare nelle vicinanze del prodotto durante il funzionamento. L'applicazione non può essere utilizzata da bambini, da persone con ridotte capacità fisiche, mentali, sensoriali o da persone prive di esperienza o del necessario addestramento. Tenere inoltre fuori dalla portata dei bambini radiocomandi o qualsiasi altro datore di impulso, per evitare che l'automazione possa essere azionata involontariamente
14. Il transito tra le ante deve avvenire solo a cancello completamente aperto
15. Tutti gli interventi di manutenzione, riparazione o verifiche periodiche devono essere eseguiti da personale professionalmente qualificato. L'utente deve astenersi da qualsiasi tentativo di riparazione o d'intervento e deve rivolgersi esclusivamente a personale qualificato SEA. L'utente può eseguire solo la manovra manuale
16. La lunghezza massima dei cavi di alimentazione fra centrale e motori non deve essere superiore a 10m. Utilizzare cablaggi con cavi in doppio isolamento (cavi con guaina) nelle immediate vicinanze dei morsetti specie per il cavo di alimentazione (230V). Inoltre è necessario mantenere adeguatamente lontani (almeno 2.5 mm in aria) i conduttori in bassa tensione (230V) dai conduttori in bassissima tensione di sicurezza (SELV) oppure utilizzare un'adeguata guaina che fornisca un isolamento supplementare avente uno spessore di almeno 1 mm

GENERAL NOTICE FOR THE INSTALLER AND THE END-USER

1. Read carefully these Instructions before beginning to install the product. Store these instructions for future reference
2. Don't waste product packaging materials and /or circuits
3. This product was designed and built strictly for the use indicated in this documentation. Any other use, not expressly indicated here, could compromise the good condition/operation of the product and/or be a source of danger. SEAS.p.A. declines all liability caused by improper use or different use in respect to the intended one.
4. The mechanical parts must comply with Directives: Machine Regulation 2006/42/CE and following adjustments, Low Tension (2006/95/CE), Electromagnetic Consistency (2004/108/CE); Installation must respect Directives: EN12453 and EN12445.
5. Do not install the equipment in an explosive atmosphere.
6. SEAS.p.A. is not responsible for failure to observe Good Techniques in the construction of the locking elements to motorize, or for any deformation that may occur during use.
7. Before attempting any job on the system, cut out electrical power and disconnect the batteries. Be sure that the earthing system is perfectly constructed, and connect to it the metal parts of the gate
8. Use of the indicator-light is recommended for every system, as well as a warning sign well-fixed to the frame structure.
9. SEA declines all liability concerning the automated system safety and efficiency, if components used are not produced by SEA
10. For maintenance, strictly use original parts by SEA.
11. Do not modify in any way the components of the automated system.
12. The installer shall supply all information concerning the system manual functioning in case of emergency and shall hand over to the user the warnings handbook supplied with the product.
13. Do not allow children or adults to stay near the product while it is operating. The application cannot be used by children, by people with reduced physical, mental or sensorial capacity or by people without experience or necessary training. Keep remote controls or other pulse generators away from children, to prevent involuntary activation of the system.
14. Transit through the leaves is allowed only when the gate is fully open.
15. The User must not attempt to repair or to take direct action on the system and must solely contact qualified SEA personnel or SEA service centers. The User can apply only the manual function of emergency.
16. The power cables maximum length between the central engine and motors should not be greater than 10 m. Use cables with 2,5 mm² section. Use double insulation cable (cable sheath) to the immediate vicinity of the terminals, in particular for the 230V cable. Keep an adequate distance (at least 2.5 mm in air), between the conductors in low voltage (230V) and the conductors in low voltage safety (SELV) or use an appropriate sheath that provides extra insulation having a thickness of 1 mm.

CONSIGNES POUR L'INSTALLATEUR ET L'UTILISATEUR

1. Lire attentivement les instructions avant d'installer le produit. Conserver les instructions en cas de besoin.
2. Ne pas disperser dans l'environnement le matériel d'emballage du produit et/ou des circuits.
3. Ce produit a été conçu et construit exclusivement pour l'usage indiqué dans cette documentation. Toute autre utilisation non expressément indiquée pourrait compromettre l'intégrité du produit et/ou être une source de danger. L'utilisation inappropriée est également cause d'annulation de la garantie. SEA S.p.A. N'assume aucune responsabilité pour une utilisation inappropriée ou une utilisation autre que celle pour laquelle l'automatisme est destiné.
4. Les composants doivent répondre aux prescriptions des Normes: Machines (2006/42/CE et successifs changements); Basse Tension (2006/95/CE et successifs changements); EMC (2004/108/CE et successifs changements). L'installation doit être effectuée conformément aux Normes EN 12453 et EN 12445.
5. Ne pas installer l'appareil dans une atmosphère explosive.
6. SEAS.p.A. n'est pas responsable du non-respect de la Bonne Technique de construction des fermetures à motoriser, ni des déformations qui pourraient intervenir lors de l'utilisation.
7. Couper l'alimentation électrique et déconnecter la batterie avant toute intervention sur l'installation. Vérifier que la mise à terre est réalisée selon les règles de l'art et y connecter les pièces métalliques de la fermeture.
8. On recommande que toute installation soit dotée au moins d'une signalisation lumineuse, d'un panneau de signalisation fixé de manière appropriée sur la structure du portail
9. SEAS.p.A. décline toute responsabilité quant à la sécurité et au bon fonctionnement de l'automatisme si les composants utilisés dans l'installation ne sont pas de production SEA
10. Utiliser exclusivement, pour l'entretien, des pièces SEA originales.
11. Ne jamais modifier les composants d'automatisme.
12. L'installateur doit fournir toutes les informations relatives au fonctionnement manuel du système en cas d'urgence et remettre à l'utilisateur qui utilise l'installation les "Instructions pour l'utilisateur" fournies avec le produit.
13. Interdire aux enfants ou aux tiers de stationner près du produit durant le fonctionnement. Ne pas permettre aux enfants, aux personnes ayant des capacités physiques, mentales et sensorielles limitées ou dépourvues de l'expérience ou de la formation nécessaires d'utiliser l'application en question. Eloigner de la portée des enfants les radiocommandes ou tout autre générateur d'impulsions, pour éviter tout actionnement involontaire de l'automatisme.
14. Le transit entre les vantaux ne doit avoir lieu que lorsque le portail est complètement ouvert.
15. L'utilisateur doit s'abstenir de toute tentative de réparation ou d'intervention et doit s'adresser uniquement et exclusivement au personnel qualifié SEA ou aux centres d'assistance SEA. L'utilisateur doit garder la documentation de la réparation. L'utilisateur peut exécuter seulement la manœuvre manuelle.
16. La longueur maximum des câbles d'alimentation entre la carte électronique et les moteurs ne devrait pas être supérieure à 10 m. Utilisez des câbles avec une section de 2,5 mm². Utilisez des câbles à double isolation (avec gaine) jusqu'à proximité immédiate des terminaux, en particulier pour le câble d'alimentation (230V). Il est également nécessaire de maintenir une distance suffisante (au moins 2.5 mm dans l'air), entre les conducteurs en basse tension (230V) et les conducteurs de très basse tension de sécurité (SELV) ou utiliser une gaine ayant une épaisseur d'au moins 1 mm, qui fournisse une isolation supplémentaire.

DECLARATION OF CONFORMITY DICHIARAZIONE DI CONFORMITÀ

SEA S.p.A. declares under its proper responsibility and, if applicable, under the responsibility of its authorised representative that, by installing the appropriate safety equipment and noise filtering, the products:

La SEA S.p.A. dichiara sotto la propria responsabilità e, se applicabile, del suo rappresentante autorizzato che, con l'installazione degli adeguati dispositivi di sicurezza e di filtraggio disturbi, i prodotti:

DESCRIPTION - DESCRIZIONE	MODEL - MODELLO	TRADEMARK - MARCA
SATURN 600 (AND ALL ITS BY-PRODUCTS - E TUTTI I SUOI DERIVATI)	12400207	SEA
SATURN 1000 (AND ALL ITS BY-PRODUCTS - E TUTTI I SUOI DERIVATI)	12400120	SEA
SATURN 1200 OIL 24V (AND ALL ITS BY-PRODUCTS - E TUTTI I SUOI DERIVATI)	12400280	SEA
SATURN 1500 OIL 24V (AND ALL ITS BY-PRODUCTS - E TUTTI I SUOI DERIVATI)	12400285	SEA
SATURN 800 BR 36V FM (AND ALL ITS BY-PRODUCTS - E TUTTI I SUOI DERIVATI)	12400270	SEA
SATURN 800 BR 36V FI (AND ALL ITS BY-PRODUCTS - E TUTTI I SUOI DERIVATI)	12400400	SEA
BOXER 600 (AND ALL ITS BY-PRODUCTS - E TUTTI I SUOI DERIVATI)	12400210	SEA
BOXER 1000 (AND ALL ITS BY-PRODUCTS - E TUTTI I SUOI DERIVATI)	12405000	SEA
BOXER 1300 INVERTER (AND ALL ITS BY-PRODUCTS - E TUTTI I SUOI DERIVATI)	12405001	SEA
BOXER 2000 INVERTER (AND ALL ITS BY-PRODUCTS - E TUTTI I SUOI DERIVATI)	12405295	SEA

are built to be integrated into a machine or to be assembled with other machinery to create a machine under the provisions of Directive 2006/42/CE;
comply with the essential safety requirements related to the products within the field of applicability of the Community Directives 2014/35/UE and 2014/30/UE

*sono costruiti per essere incorporati in una macchina o per essere assemblati con altri macchinari per costruire una macchina ai sensi della Direttiva 2006/42/CE;
sono conformi ai requisiti essenziali di sicurezza relativi ai prodotti entro il campo di applicabilità delle Direttive Comunitarie 2014/35/UE e 2014/30/UE*

THE MANUFACTURER OR THE AUTHORIZED REPRESENTATIVE
IL COSTRUTTORE o IL RAPPRESENTANTE AUTORIZZATO

SEA S.P.A.
ZONA INDUSTRIALE SANT'ATTO
64100 - TERAMO - ITALY
+ 39 0 861 588341
www.seateam.com

PLACE AND DATE OF ISSUE
LUOGO E DATA DI EMISSIONE

TERAMO, 06/09/2022

L'Amministratore
The Administrator
Ernio Di Saverio



SEA®



Automatic Gate Openers

International registered trademark n. 804888

SEA S.p.A.

Zona Industriale Sant'Atto - 64100 - Teramo - ITALY

Tel. +39 0 861 588341 r.a. Fax +39 0 861 588344

www.seateam.com