

LEPUS INDUSTRIAL

MOTORIDUTTORE PER CANCELLI SCORREVOLI
MOTOR REDUCER FOR SLIDING GATES
MOTEUR POUR PORTAILS COULISSANTS



SEA S.p.A.

Zona Industriale Sant'Atto - 64100 - Teramo - ITALY

Telephone: + 39 0 861 588341

www.seateam.com

1
GENERAL FEATURES

LEPUS INDUSTRIAL is an oil-bathed motor-reducer designed for the automation of sliding gates. All **LEPUS INDUSTRIAL** are **IRREVERSIBLE** but a **REVERSIBLE** model is available (**LEPUS INDUSTRIAL 1000 REVERSIBLE with electric brake**). The irreversibility of the gearmotor allows a perfect and safe closing of the gate avoiding the installation of the electric lock. Furthermore, the **RELEASE SYSTEM** - placed on the front part of the external box - allows the manual opening and closing in the event of a power failure. The operator is also equipped with an **ADJUSTABLE MECHANICAL CLUTCH** which guarantees the control of the gate thrust. Moreover, the **ELECTRONIC INVERSION SYSTEM** through **ENCODER**, makes the **LEPUS INDUSTRIAL** a safe and reliable operator, allowing the inversion on obstacle as often required by the Safety Regulations in force in many Countries; SEA always recommends to read and respect them.

COMPONENTS

Fig. 1

LEPUS INDUSTRIAL 36V BR IN THE EXAMPLE

- 1 - EXTERNAL BOX
- 2 - TERMINAL FOR ELECTRIC WIRINGS
- 3 - SWITCHING POWER SUPPLY
- 4 - ABSOLUTE ENCODER (OR LIMIT SWITCH)*
- 5 - ADJUSTABLE FOUNDATION PLATE
- 6 - ANCHOR BOLTS
- 7 - ELECTRONIC CONTROL UNIT
- 8 - ENCODER ABC
- 9 - ELECTRIC MOTOR
- 10 - OIL LEVEL CHECKING CAP (CHAPTER 10)
- 11 - PINION Z16 (OPTIONAL M4 Z13 OR Z20 M4)
- 12 - MANUAL RELEASE WITH KEY

* LEPUS INDUSTRIAL is also available with limit switch

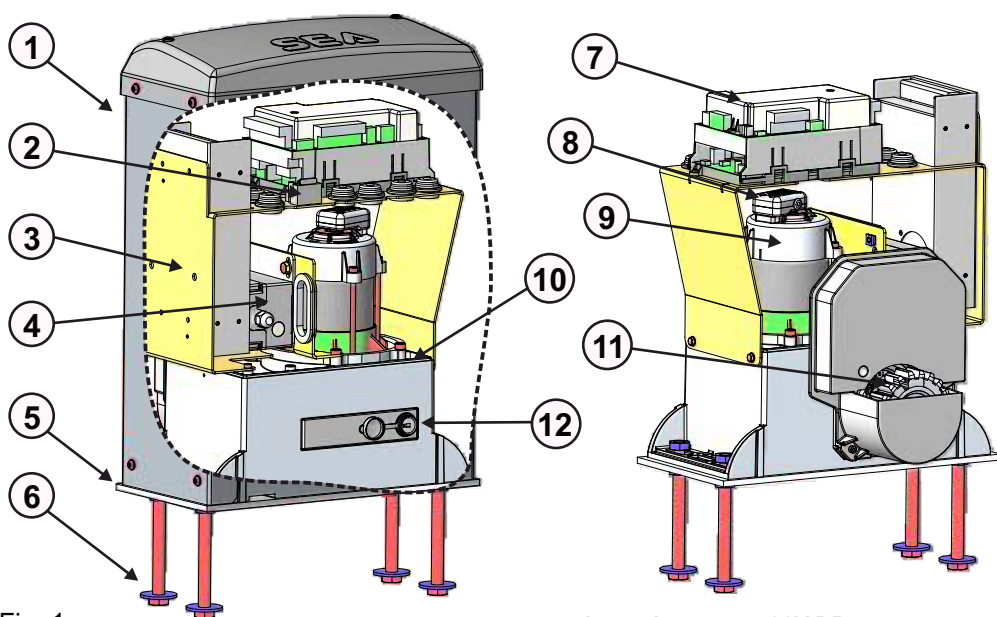
DIMENSIONS (mm)

Fig. 2a

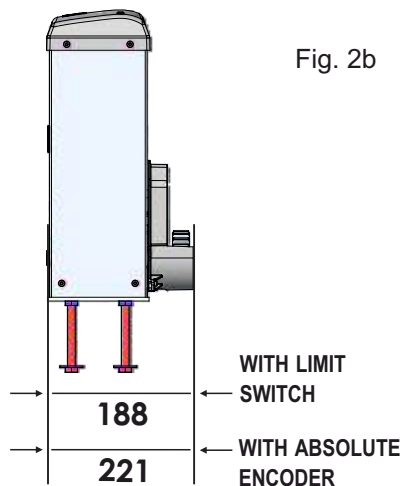
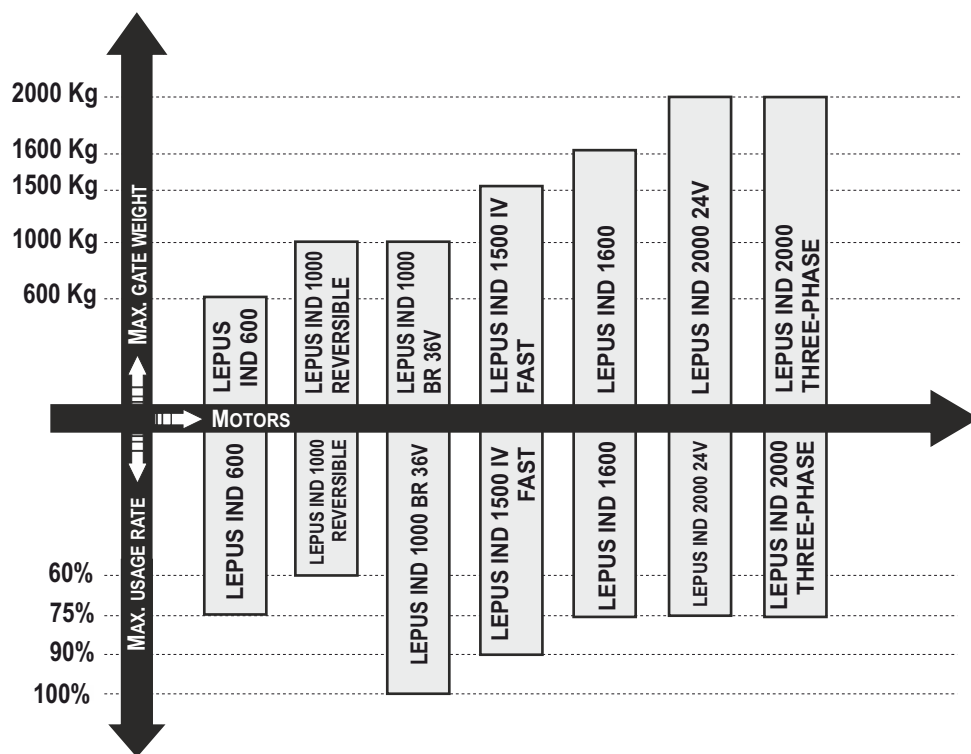

Fig. 2b

APPLICATION CHART

TECHNICAL DATA CHARTS

TECHNICAL DATA	LEPUS IND 1000 BR	LEPUS IND 1000 REV	LEPUS 1500 IV FAST
POWER SUPPLY	36V - 230V (±5%) 50/60 Hz	230V (±5%) 50/60 Hz	230V (±5%) 50/60 Hz
MOTOR POWER	330W	330W	500W
STARTING CAPACITOR	-	25 µF	-
USAGE RATE *	100%	60%	90%
MOTOR ROTATION SPEED	2800 rpm	1400 rpm	2800 rpm
REDUCTION RATIO	1/30	1/30	1/30
OPERATING TEMPERATURE	-20°C +55°C	-20°C +55°C	-20°C +55°C
THERMAL PROTECTION	-	130°C	-
OPERATOR WEIGHT (WITH OIL)	17 Kg	17 Kg	17 Kg
OIL TANK CAPACITY	1 L	1,75 L	1,75 L
PROTECTION CLASS	IP 55	IP 55	IP 55
Z13 PINION SPEED	-	-	-
Z16 PINION SPEED	0,30 m/s	0,13 m/s	0,39 m/s
Z20 PINION SPEED	-	-	0,49 m/s
MAXIMUM TORQUE	70Nm	70Nm	70Nm
GATE MAX. WEIGHT	1000 Kg	1000 Kg	1500 Kg
ANTI-CRUSHING CLUTCH	-	MECHANICAL	MECHANICAL
LIMIT SWITCH OR ABSOLUTE ENCODER	ABSOLUTE ENCODER	Mechanical or Absolute encoder	MECHANICAL LIMIT SWITCH
ELECTRIC BRAKE	No	YES	No

TECHNICAL DATA	LEPUS IND 1600	LEPUS IND 2000 24V	LEPUS IND 2000 THREEPHASE
POWER SUPPLY	230V (±5%) 50/60 Hz	24V	400V/230V~ (±5%) 50/60 Hz
MOTOR POWER	450W	100W	650W
STARTING CAPACITOR	35 µF	-	-
USAGE RATE *	75%	75%	75% INTENSIVE
MOTOR ROTATION SPEED	1400 rpm	3500 rpm	1400 rpm
REDUCTION RATIO	1/30	1/30	1/30
OPERATING TEMPERATURE	-20°C +55°C	-20°C +55°C	-20°C +55°C
THERMAL PROTECTION	130°C	-	-
OPERATOR WEIGHT (WITH OIL)	17 Kg	17 Kg	17 Kg
OIL TANK CAPACITY	1,75 L	1 L	1,75 L
PROTECTION CLASS	IP 55	IP 55	IP 55
Z13 PINION SPEED	0,125 m/s	0,28 m/s (2000 Kg)	0,125 m/s
Z16 PINION SPEED	0,175 m/s	0,35 m/s (1000 Kg)	0,175 m/s
Z20 PINION SPEED	0,2 m/s	0,455 m/s (400 Kg)	0,2 m/s
MAXIMUM TORQUE	70Nm	70Nm	90Nm
GATE MAX. WEIGHT	1600 Kg	2000 Kg	2000 Kg
ANTI-CRUSHING CLUTCH	MECHANICAL	MECHANICAL	MECHANICAL
LIMIT SWITCH OR ABSOLUTE ENCODER	MECHANICAL LIMIT SWITCH	MECHANICAL LIMIT SWITCH	Mechanical or Absolute encoder
ELECTRIC BRAKE	No	No	No

* The indicated usage rate is valid only for the first operating hour and at a 20°C temperature

FOR VERSIONS WITH ABSOLUTE ENCODER, the maximum gate length depends on the type of pinion:

Z13/M4 → max. 10,5 m - Z16/M4 → max. 13 m - Z20/M4 → max. 16 m

3
GATE ARRANGEMENT

Before the installation, check that all gate parts (fixed and mobile) have a strong and non-deformable structure; also make the following checks:

- 3.1. The gate must be rigid and compact;
- 3.2. The lower gate slideway must be perfectly straight, horizontal and without any obstacles which could obstruct the gate sliding;
- 3.3. The lower sliding wheels must be equipped with greasable or watertightened bearings;
- 3.4. The upper slideway must be perfectly straight and placed so that the gate could be in vertical position;
- 3.5. *The mechanical stops of the gate must always be installed in order to avoid any possible derailment*

4
INSTALLATION OF THE FOUNDATION PLATE

To install the foundation plate it is necessary to:

4.1. Prepare a concrete basement according to the dimensions shown in Fig. 3; The foundation plate and the anchor bolts must be concreted inside the basement

IF ALLOWED BY THE GATE STRUCTURE, IT IS RECOMMENDED TO LIFT THE FOUNDATION PLATE OF ABOUT 50mm FROM THE GROUND, IN ORDER TO AVOID EVENTUAL WATER STAGNATION.

4.2. Before cementing the plate insert a flexible plastic pipe of at least **30 mm** in diameter into the special hole of the plate

4.3. Before concreting the plate, make sure that it is perfectly leveled and that the distance of **50 - 55 mm** as shown in Fig. 4 is respected

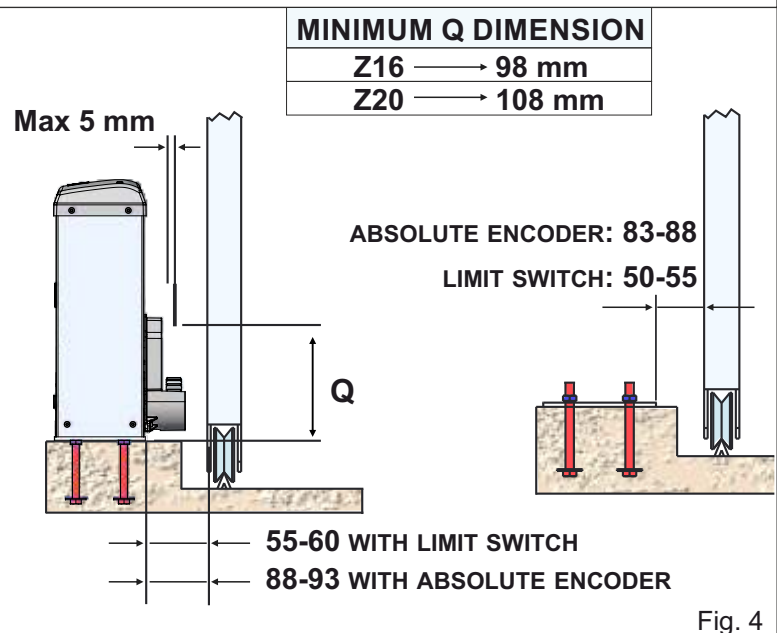
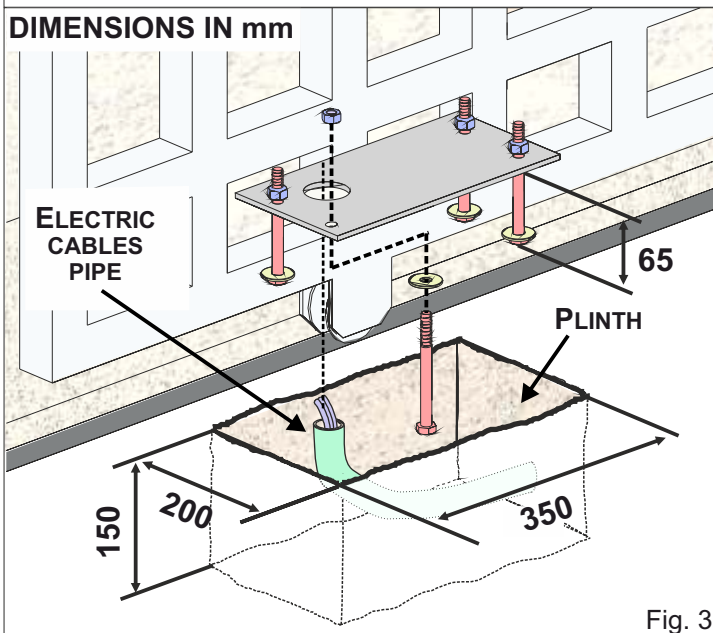
5
PINION MOUNTING - JUST IN CASE OF REPLACEMENT

If you need to replace the existing pinion, proceed as follows:

5.1. Remove the seeger and the existing pinion as shown in Fig. 5

5.2. Remove the shaft pin «A»

5.3. Insert the new spare parts (shaft pin, the seeger and the new pinion) as shown in Fig. 5

Fig. 5

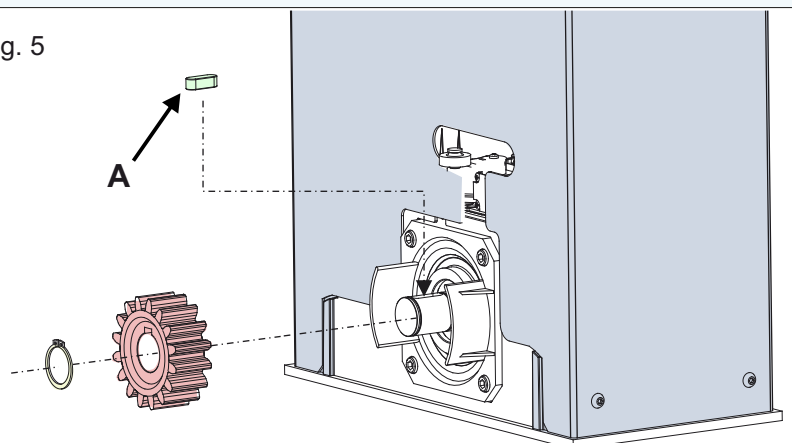

6

GEAR RACK MOUNTING

- 6.1. Release the operator and open the gate completely;
- 6.2. Fix on each gear rack element the support pawls with the appropriate lock screws, making sure to put them in the upper part of the hole - Fig. 6;
- 6.3. Lean the gear rack element on the toothed pinion of the operator in parallel to the ground slideway of the gate, as shown in Fig. 7 and electrically weld the central pawl **B** to the gate structure - Fig. 8. Manually move the gate until pawl **C** is placed in front of the pinion and fix it through electric welding. Repeat the same procedure for pawl **A** after having placed it in front of the pinion;
- 6.4. Make sure that all the gear rack elements are perfectly aligned and correctly placed (**the teeth must be in phase**). It is suggested to oppose an element to two aligned elements as shown in Fig. 9;
- 6.5. Repeat the above described operation for all the remaining gear rack elements which have to be installed;
- 6.6. To avoid that the gate weights down the pinion - Fig.10 - lift up the whole rack of about 1,5 mm. **CAUTION! KEEP A GAP OF ABOUT 0,5 mm BETWEEN THE PINION TOOTH AND THE GEAR RACK TOOTH;**
- 6.7. Make sure that the gear rack works at the midpoint of the pinion along all the rack elements, if necessary, adjust the length of the spacers

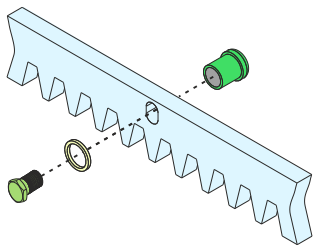

Fig. 6

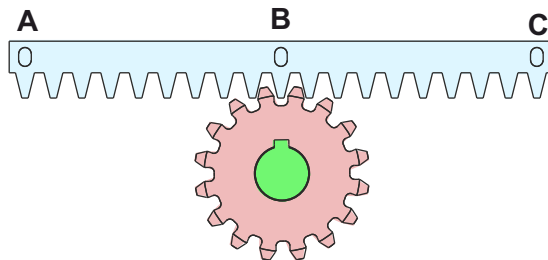

Fig. 7

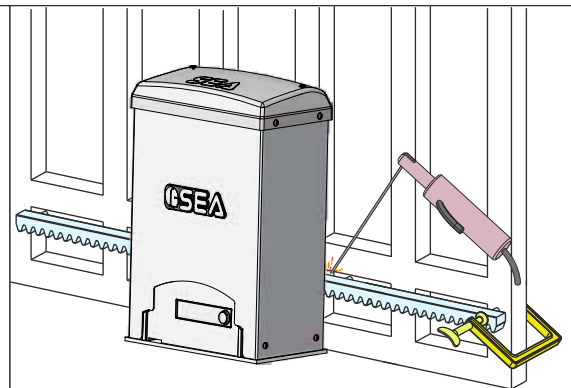

Fig. 8

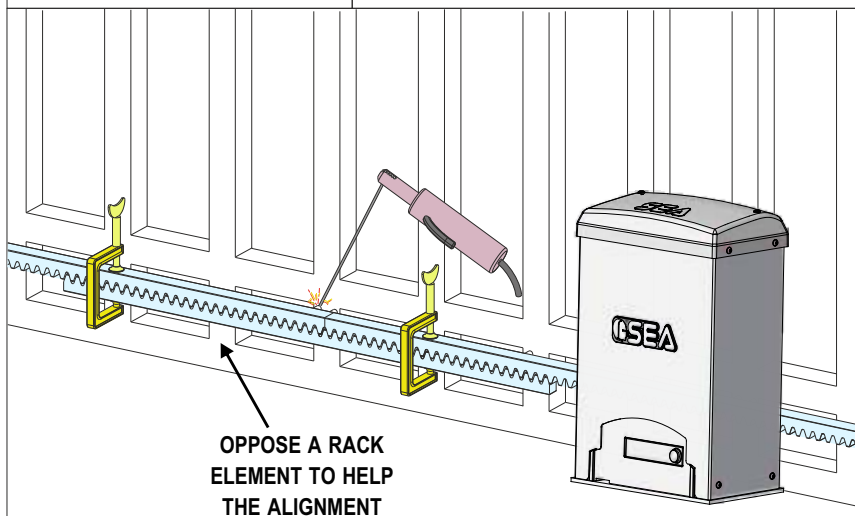

Fig. 9

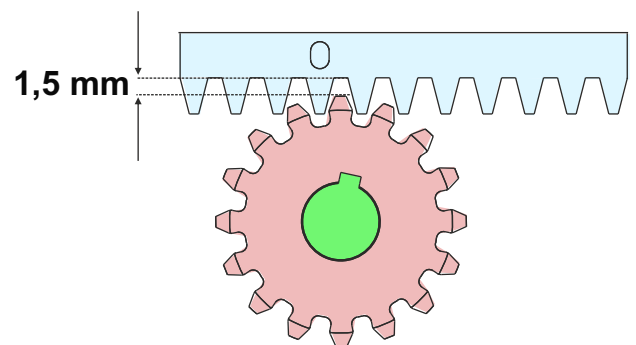

Fig. 10

7 INSTALLATION OF THE OPERATOR

- 7.1.** Fix the gearmotor to the foundation plate by the use of the supplied screws - Fig. 11 , then adjust its lateral position and height - Fig. 12 - to comply with the dimensions mentioned in Fig. 4
- 7.2.** *Be careful to correctly insert the plate «A» into the housing and fasten it to the gearmotor as shown in Fig. 11*

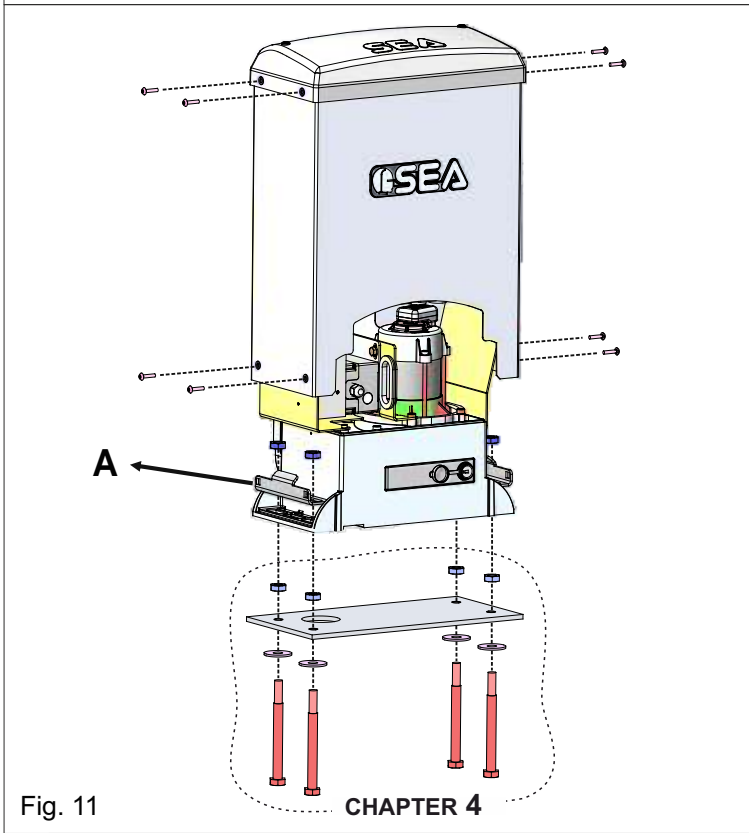

Fig. 11



Fig. 12

⚠ BEFORE STARTING UP THE OPERATOR, CARRY OUT THE FOLLOWING ADJUSTMENTS, ACCORDING TO THE MODEL IN USE, IN PARTICULAR REMEMBER TO REPLACE THE BREATHER CAP BEFORE STARTING UP.

8 LIMIT SWITCH ADJUSTMENT - JUST FOR MODELS WITH LIMIT SWITCH

- 8.1. IN OPENING**
- Manually move the gate wide open
 - Place the plate on the rack according to the desired gate stop position; fix the plate on the rack using the screws - Fig. 14
- 8.2. IN CLOSING**
- Manually close the gate
 - Place the plate on the rack according to the desired gate stop position; fix the plate on the rack using the screws - Fig. 14

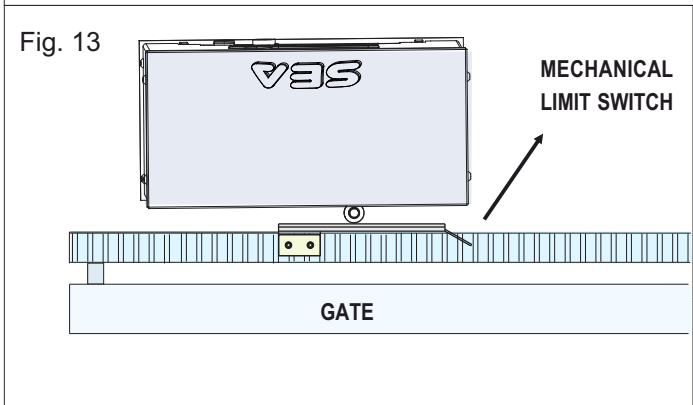

Fig. 13

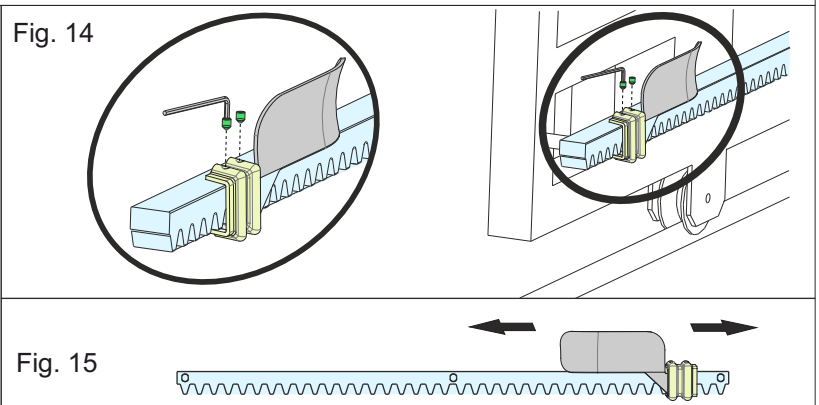

Fig. 14

Fig. 15

➡ AFTER STARTING THE OPERATOR, IT MAY BE NECESSARY TO MANUALLY ADJUST THE PLATES, BOTH IN OPENING AND CLOSING. ANY FURTHER ADJUSTMENTS ALSO CAN BE MADE ON THE ELECTRONIC CONTROL UNIT!

9
CLUTCH ADJUSTMENT - JUST FOR MODELS WITH OPTIONAL CLUTCH

9.1. Switch off the electric power supply

9.2. To adjust the clutch, act on the grub screw «A» Fig. 16 - as follows:

- **CLOCKWISE DIRECTION** = less clutch sensitivity - more thrust force
- **COUNTER-CLOCKWISE DIRECTION** = more clutch sensitivity - less thrust force

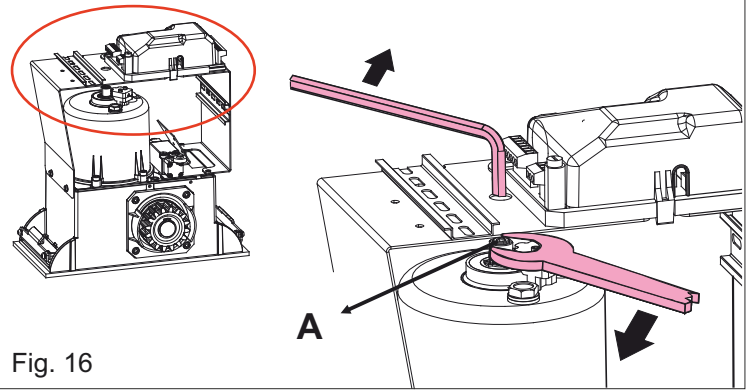

Fig. 16

10
BREATHER CAP REPLACEMENT (OIL LEVEL CHECKING CAP)

10.1. **BEFORE STARTING UP THE OPERATOR, REMOVE THE RED TRANSPORT CAP** and replace it with the black cap supplied and equipped with the airhole

10.2. Depending on the model, the cap may be either on the bell-shaped reducer or behind the pinion - Fig.17 or Fig. 18

10.3. **TO TOP UP THE ENGINE OIL**, lift the black cap, top up the oil and close it again.

Fig. 17

VERSION 220V OR 110V

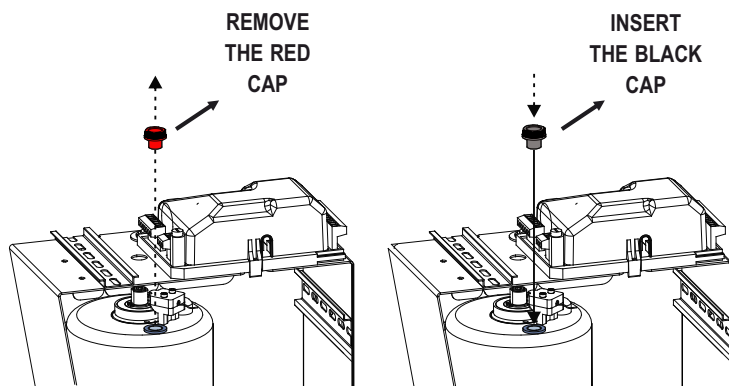
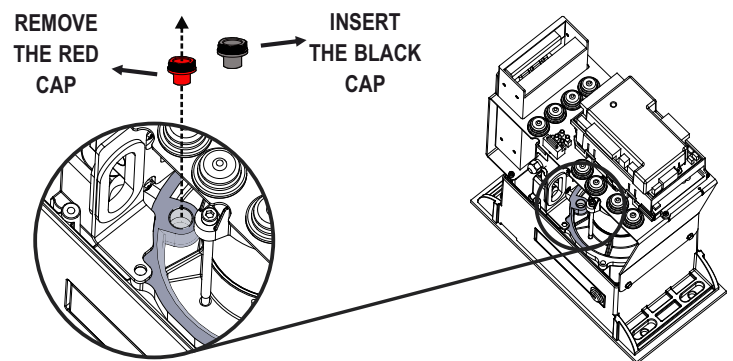

Fig. 18

VERSION 24V OR 36V

11
GROUNDING

11.1. Before connecting the operator, ensure that it is earthed, as shown in Fig. 19 or Fig. 20, depending on the model in use.

VERSION 220V o 110V

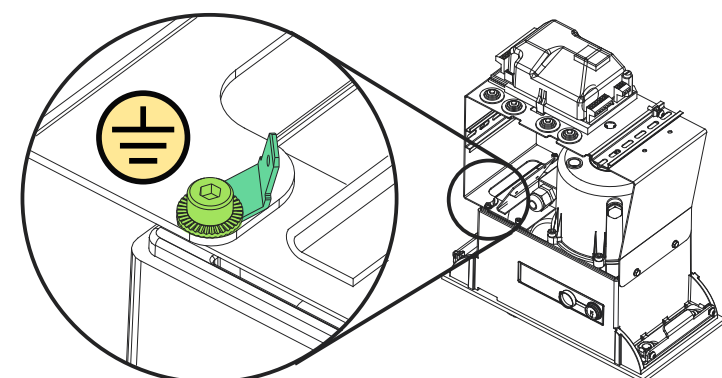

Fig. 19

VERSION 24V o 36V

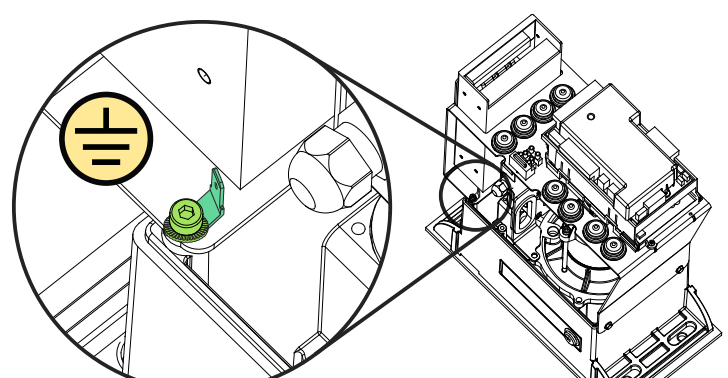
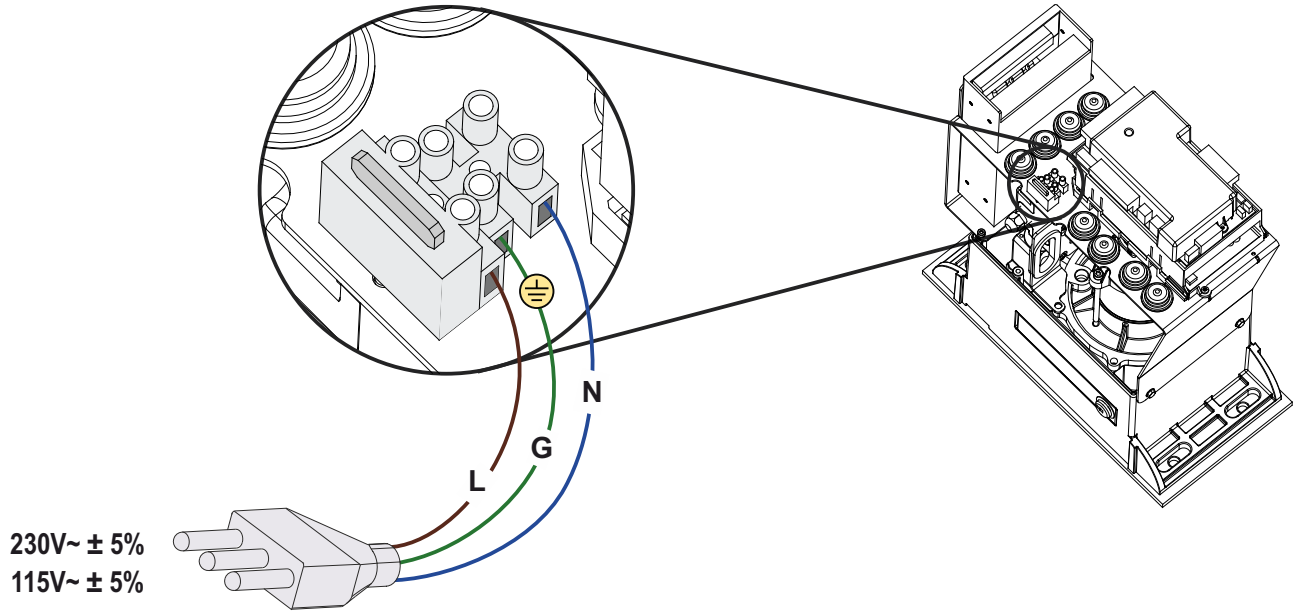
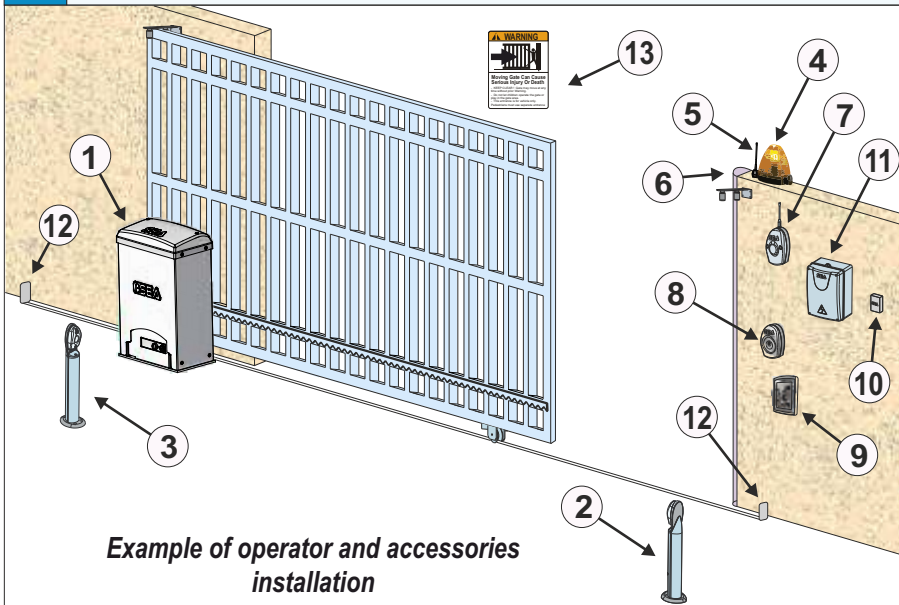

Fig. 20

12
WIRINGS ON MOTOR TERMINAL BOARD

Fig. 21

13
STANDARD INSTALLATION WIRING

RECOMMENDED CABLES NUMBER AND SECTION FOR WIRINGS ON CONTROL UNIT

1) OPERATOR	→	4 x 1,5
2) PHOTOCELL TX	→	2 x 0,5
3) PHOTOCELL RX	→	4 x 0,5
4) FLASHING LAMP	→	2 x 0,5
5) ANTENNA	→	1 x RG58
6) SAFETY EDGE	→	2 x 0,5 *
7) EXTERNAL RECEIVER	→	4 x 0,5
8) KEY-BUTTON	→	4 x 0,5
9) KEYPAD	→	4 x 0,5
10) DIFFERENTIAL 16A/30mA	→	3 x 1,5 **
11) CONTROL UNIT BOX		
12) END-OF-STROKE MECHANICAL STOPS		
13) WARNING SIGNS		

* In case of powered safety edge: 4 x 0,5

** Increase the cable section in case of high distance from the control unit

Fig. 22

PART FOR BOTH INSTALLER AND END-USER

ALL THE UNLOCKING AND LOCKING OPERATIONS AND ALL PERIODIC MAINTENANCE OPERATIONS MUST BE CARRIED OUT IN ABSENCE OF POWER SUPPLY!

14
RELEASE SYSTEM
14.1. TO RELEASE THE OPERATOR

- Open the lock cover, insert the key and rotate 90° clockwise - Fig. 23 - 24
- Pull the release lever until it stops, about 90° - Fig. 25

*when pulling the release lever, the control unit receives a safety stop impulse thanks to a micro-switch inside the operator (anyway, **it is highly recommended to switch OFF the power supply before**)*

14.2. TO LOCK THE OPERATOR

- Push the release lever to the complete closing
- Rotate the key counter-clockwise and extract it
- Close the protective lock cover

Once the lock has been restored the electronic control unit reactivates - if the power supply was ON!

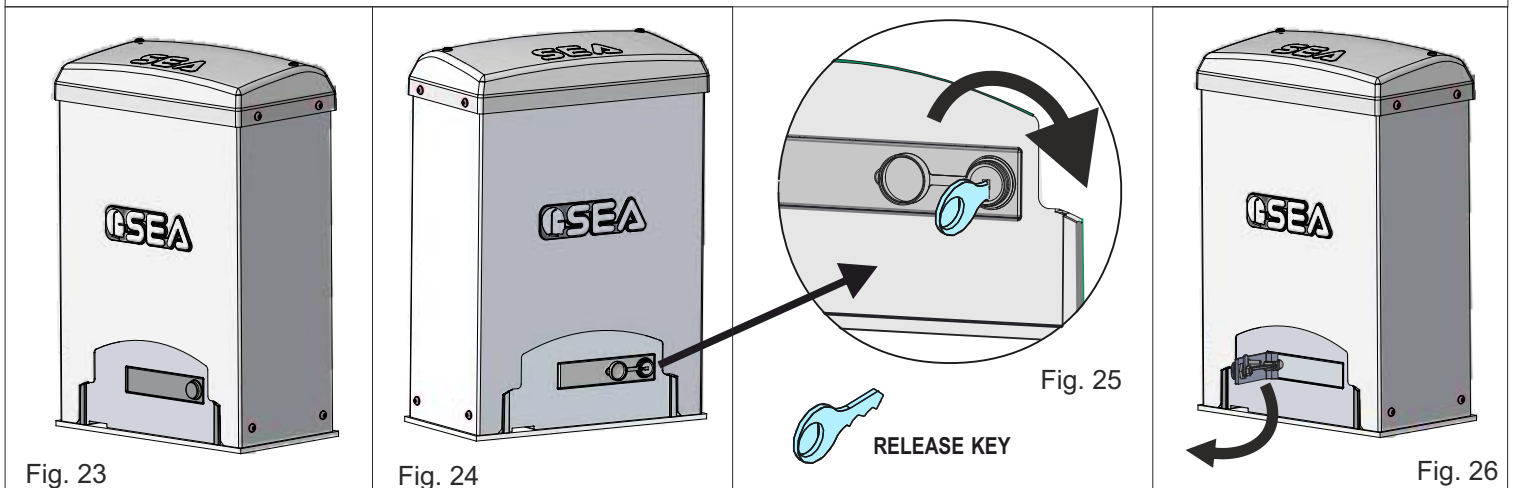
15
PERIODIC MAINTENANCE - FOR INSTALLERS ONLY!

CHECK THE OIL LEVEL	ANNUAL
CHANGE THE OIL	4 YEARS
CHECK THE CORRECT OPERATION OF THE RELEASE SYSTEM	ANNUAL
CHECK THE CORRECT OPERATION OF THE CLUTCH (JUST FOR MODELS WITH CLUTCH)	ANNUAL
CHECK THE DISTANCE BETWEEN PINION AND GEAR RACK (1.5 mm)	ANNUAL
CHECK THE CONDITION OF THE PINION AND THE GEAR RACK (IF OVERUSED OR DAMAGED)	ANNUAL
CHECK ALL THE FASTENING SCREWS	ANNUAL
CHECK THE CONDITION OF THE ELECTRIC CABLES	ANNUAL
CHECK THE CORRECT OPERATION OF THE LIMIT SWITCHES IN OPENING AND CLOSING; ALSO CHECK THE CONDITION OF THE STOP PLATES	ANNUAL



ALL OPERATIONS MUST BE CARRIED OUT EXCLUSIVELY BY AN AUTHORIZED INSTALLER

ALL OPERATIONS MUST BE CARRIED OUT IN ABSENCE OF POWER SUPPLY

PART FOR BOTH INSTALLER AND END-USER

GENERAL NOTICE

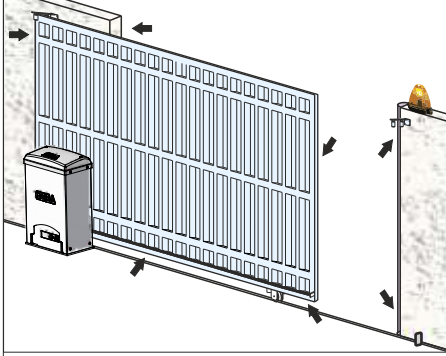

RISK EXAMINATION: The points pointed by arrows are potentially dangerous. The installer must take a thorough risk examination to prevent crushing, conveying, cutting, grappling, trapping so as to guarantee a safe installation for people, things and animals (Re. Laws in force in the Country where installation has been made). As for misunderstandings that may arise refer to your area distributor or call our help desk. These instructions are part of the device and must be kept in a well known place. The installer shall follow the provided instructions thoroughly. SEA products must only be used to automate doors, gates and wings. Any initiative taken without SEA explicit authorization will preserve the manufacturer from whatsoever responsibility. The installer shall provide warning notices on not assessable further risks. SEA in its relentless aim to improve the products, is allowed to make whatsoever adjustment

without giving notice. This doesn't oblige SEA to upgrade the past production. SEA cannot be deemed responsible for any damage or accident caused by product breaking, being damages or accidents due to a failure to comply with the instructions herein. The guarantee will be void and the manufacturer responsibility will be nullified if SEA original spare parts are not being used. The electrical installation shall be carried out by a professional technician who will release documentation as requested by the laws in force. Packaging materials such as plastic bags, foam polystyrene, nails etc must be kept out of children's reach as dangers may arise.

INITIAL TEST AND STARTING OF THE AUTOMATION: After having completed the necessary operations for a correct installation of the product and after having evaluated all the risks which could arise in any installation, **it is necessary to test the automation to guarantee the maximum safety and to guarantee that the Laws in force are fully respected.** The first Start must be executed according to the rule **EN 12445** which establishes the methods of tests for checking the gate automation respecting the limits established by the rule **EN 12453**

SAFETY PRECAUTIONS: All electrical works should comply with the current regulations. A 16A/0,030 differential switch must be used. Separate the source cables (operators, power supply) and command cables (photocells, push-buttons, etc). Be sure the entire system is properly grounded. Always run cables in separate ducts to prevent interferences

INTENDED USE: The operator has been designed to be used for the automation of sliding gates only

SPARE PARTS: Send request for spare parts to: **SEA S.p.A. - Teramo - ITALY - www.seateam.com**

SAFETY AND ENVIRONMENTAL COMPATIBILITY: Don't waste product packing materials and/or circuits

STORAGE: T = -30°C/+60°C ; Humidity = min. 5% / max. 90% (without condensation); Materials must be properly packaged, handled with care and with appropriate vehicles

WARRANTY LIMITS - see the sales conditions

MAINTENANCE AND DECOMMISSION: must only be carried out by specialized and authorized personnel

THE MANUFACTURER CAN NOT BE DEEMED RESPONSIBLE FOR ANY DAMAGE OR INJURY CAUSED BY IMPROPER USE OF THIS PRODUCT

SEA S.p.A. reserves the right to make any required modification or change to the products and/or to this manual without any advanced notice obligation.

1. Read carefully these instructions before beginning to install the product. Store these instructions for future reference
2. Don't waste product packaging materials and /or circuits
3. This product was designed and built strictly for the use indicated in this documentation. Any other use, not expressly indicated here, could compromise the good condition/operation of the product and/or be a source of danger. SEAS.p.A. declines all liability caused by improper use or different use in respect to the intended one.
4. The mechanical parts must comply with Directives: Machine Regulation 2006/42/CE and following adjustments, Low Tension (2006/95/CE), Electromagnetic Consistency (2004/108/CE); Installation must respect Directives: EN12453 and EN12445.
5. Do not install the equipment in an explosive atmosphere.
6. SEA is not responsible for failure to observe Good Techniques in the construction of the locking elements to motorize or for any deformation that may occur during use
7. Before attempting any job on the system, cut out electrical power and disconnect the batteries. Be sure that the grounding system is perfectly constructed, and connect to it the metal parts of the gate
8. Use of the indicator-light is recommended for every system, as well as a warning sign well-fixed to the frame structure.
9. SEA declines all liability concerning the automated system safety and efficiency, if components used are not produced by SEA
10. For maintenance, strictly use original parts by SEA.
11. Do not modify in any way the components of the automated system.
12. The installer shall supply all information concerning the system manual functioning in case of emergency and shall hand over to the user the warnings handbook supplied with the product.
13. Do not allow children or adults to stay near the product while it is operating. The application cannot be used by children, by people with reduced physical, mental or sensorial capacity or by people without experience or necessary training. Keep remote controls or other pulse generators away from children, to prevent involuntary activation of the system.
14. Transit through the leaves is allowed only when the gate is fully open.
15. The User must not attempt to repair or to take direct action on the system and must solely contact qualified SEA personnel or SEA service centers. The User can apply only the manual function of emergency.
16. The power cables maximum length between the central engine and motors should not be greater than 10 m. Use cables with 2,5 mm² section. Use double insulation cable (cable sheath) to the immediate vicinity of the terminals, in particular for the 230V cable. Keep an adequate distance (at least 2.5 mm in air), between the conductors in low voltage (230V) and the conductors in safety low voltage (SELV) or use an appropriate sheath that provides extra insulation having a thickness of 1 mm

DECLARATION OF CONFORMITY

DICHIARAZIONE DI CONFORMITÀ

SEA S.p.A. declares under its proper responsibility and, if applicable, under the responsibility of its authorised representative that, by installing the appropriate safety equipment and noise filtering, the products:

La SEA S.p.A. dichiara sotto la propria responsabilità e, se applicabile, del suo rappresentante autorizzato che, con l'installazione degli adeguati dispositivi di sicurezza e di filtraggio disturbi, i prodotti:

DESCRIPTION - DESCRIZIONE	MODEL - MODELLO	TRADEMARK - MARCA
LEPUS INDUSTRIAL P1000 REVERSIBLE (AND ALL ITS BY-PRODUCTS - E TUTTI I SUOI DERIVATI)	11115143	SEA
LEPUS INDUSTRIAL 2000 E/A IV (AND ALL ITS BY-PRODUCTS - E TUTTI I SUOI DERIVATI)	11110570	SEA
LEPUS INDUSTRIAL 2000 24V (AND ALL ITS BY-PRODUCTS - E TUTTI I SUOI DERIVATI)	11110525	SEA
LEPUS INDUSTRIAL 1000 36V BR E/A (AND ALL ITS BY-PRODUCTS - E TUTTI I SUOI DERIVATI)	11110550	SEA

- are built to be integrated into a machine or to be assembled with other machinery to create a machine under the provisions of Directive 2006/42/CE;
- comply with the essential safety requirements related to the products within the field of applicability of the Community Directives 2014/35/UE and 2014/30/UE
- sono costruiti per essere incorporati in una macchina o per essere assemblati con altri macchinari per costruire una macchina ai sensi della Direttiva 2006/42/CE;
- sono conformi ai requisiti essenziali di sicurezza relativi ai prodotti entro il campo di applicabilità delle Direttive Comunitarie 2014/35/UE e 2014/30/UE

THE MANUFACTURER OR THE AUTHORIZED REPRESENTATIVE
IL COSTRUTTORE o IL RAPPRESENTATE AUTORIZZATO

PLACE AND DATE OF ISSUE
LUOGO E DATA DI EMISSIONE

TERAMO, 12/03/2025

SEA S.P.A.
ZONA INDUSTRIALE SANT'ATTO
64100 - TERAMO - ITALY
+ 39 0 861 588341
www.seateam.com

L'Administratore
The Administrator
Ennio Di Saverio



SEA®



Automatic Gate Openers

International registered trademark n. 804888

SEA S.p.A.

Zona Industriale Sant'Atto - 64100 - Teramo - ITALY

Tel. +39 0 861 588341 r.a. Fax +39 0 861 588344

www.seateam.com