

# LEPUS

**MOTORIDUTTORE PER CANCELLI SCORREVOLI**  
**MOTOR REDUCER FOR SLIDING GATES**  
**MOTEUR POUR PORTAILS COULISSANTS**



**SEA S.p.A.**

Zona Industriale Sant'Atto - 64100 - Teramo - ITALY  
Telephone: + 39 0 861 588341 - Fax: + 39 0 861 588344

[www.seateam.com](http://www.seateam.com)

## GENERAL FEATURES

**LEPUS** is an oil-bathed motor-reducer designed for the automation of sliding gates.

It is **IRREVERSIBLE** to allow a perfect and safe closing of the gate avoiding the installation of the electric lock.

It is equipped with a **RELEASE SYSTEM** - placed on the front part of the external box - allows the manual opening and closing in the event of a power failure.

It is also equipped with an **ADJUSTABLE MECHANICAL CLUTCH** which guarantees the control of the gate thrust.

Moreover, the **electronic inversion system** through **ENCODER**, makes the **LEPUS** a safe and reliable operator and allows to comply with the Laws in force in the Countries where the product is installed

## COMPONENTS

Fig. 1

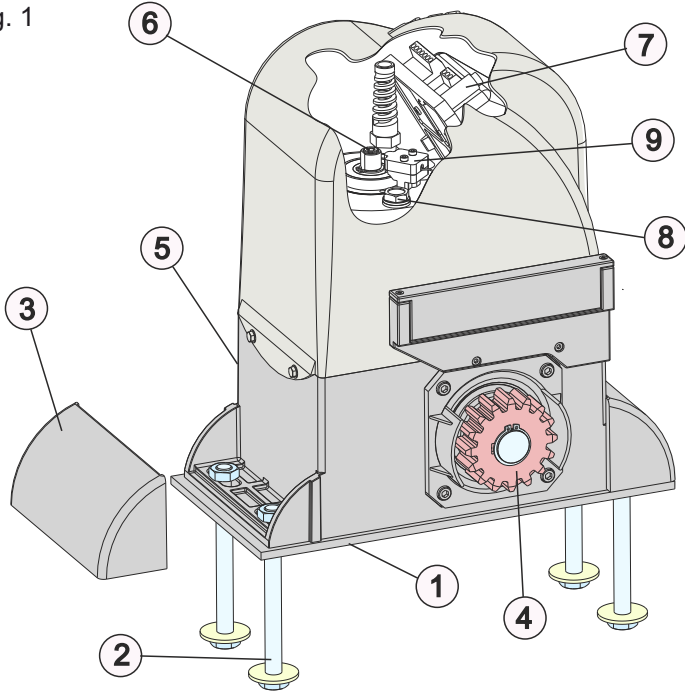

- 1 ADJUSTABLE FOUNDATION PLATE
- 2 ANCHOR BOLTS
- 3 SIDE COVER
- 4 PINION
- 5 RELEASE LEVER
- 6 ADJUSTING SCREW FOR MECHANICAL CLUTCH
- 7 ELECTRONIC CONTROL UNIT
- 8 OIL FILLER CAP
- 9 MAGNETIC ENCODER

## APPLICATION CHART

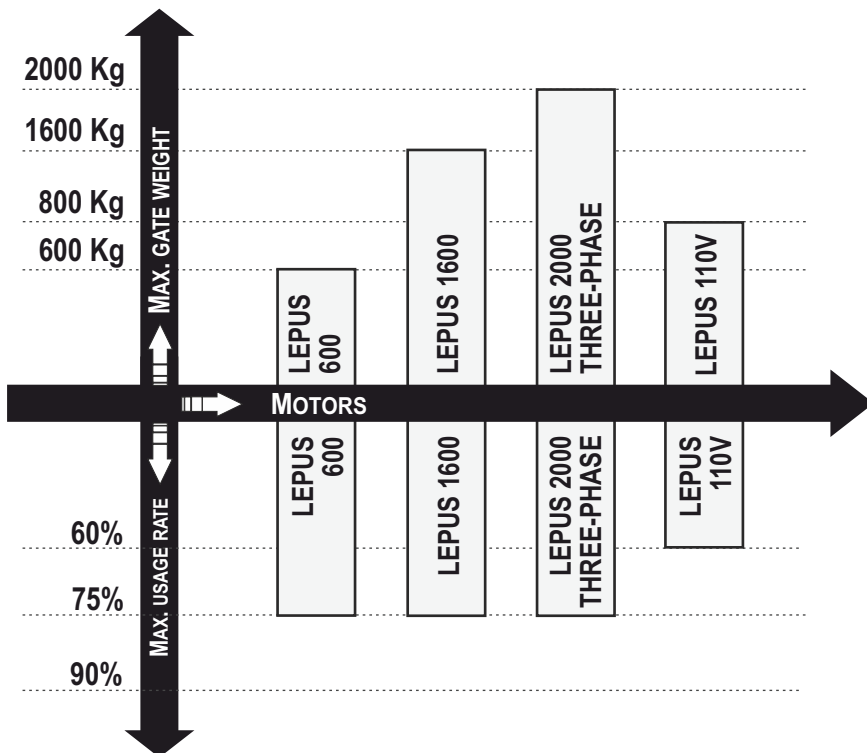

## DIMENSIONS (mm)

Fig. 2

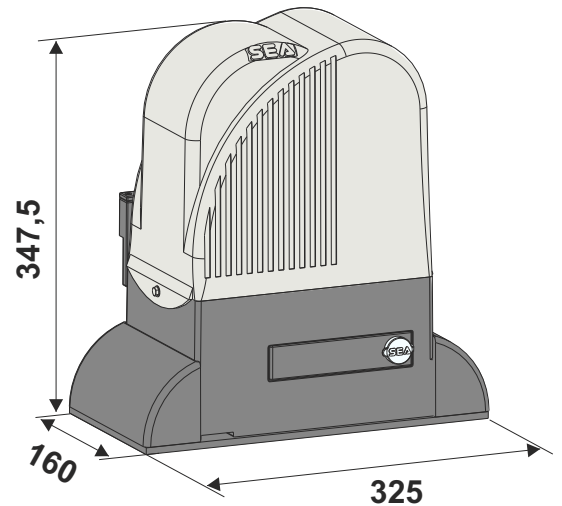

TECHNICAL DATA	LEPUS 600	LEPUS 1600	LEPUS 2000 TRIFASE	LEPUS 110V	
POWER SUPPLY	230V (±5%) 50/60 Hz			115V (±5%) 50/60 Hz	
MOTOR POWER	330 W	450 W	650 W	330 W	
STARTING CAPACITOR	25 µF	35 µF	-	80 µF	
USAGE RATE	75%			60%	
MOTOR ROTATION SPEED	1400 rpm			1550 rpm	
REDUCTION RATIO	1÷30				
OPERATING TEMPERATURE	-20°C +55°C				
THERMAL PROTECTION	130°C				
OPERATOR WEIGHT (WITH OIL)	15 Kg		15,5 Kg	15 Kg	
OIL TANK CAPACITY	1,75 L				
PROTECTION CLASS	IP 55				
Z13 PINION SPEED	0,13 m/s				
Z16 PINION SPEED	0,175 m/s				
Z20 PINION SPEED	0,2 m/s				
MAXIMUM TORQUE	50 Nm	70 Nm	90 Nm	60 Nm	
GATE MAX. WEIGHT	600 Kg	1600 Kg	2000 Kg	800 Kg	
GATE MAX. LENGTH	11 m				
ANTI-CRUSHING CLUTCH	MECHANICAL IN OIL-BATH OR ELECTRONIC				
LIMIT SWITCH	MECHANICAL WITH LEVER OR INDUCTIVE				

➔ The indicated usage rate is valid only for the first operating hour and at a 20°C temperature

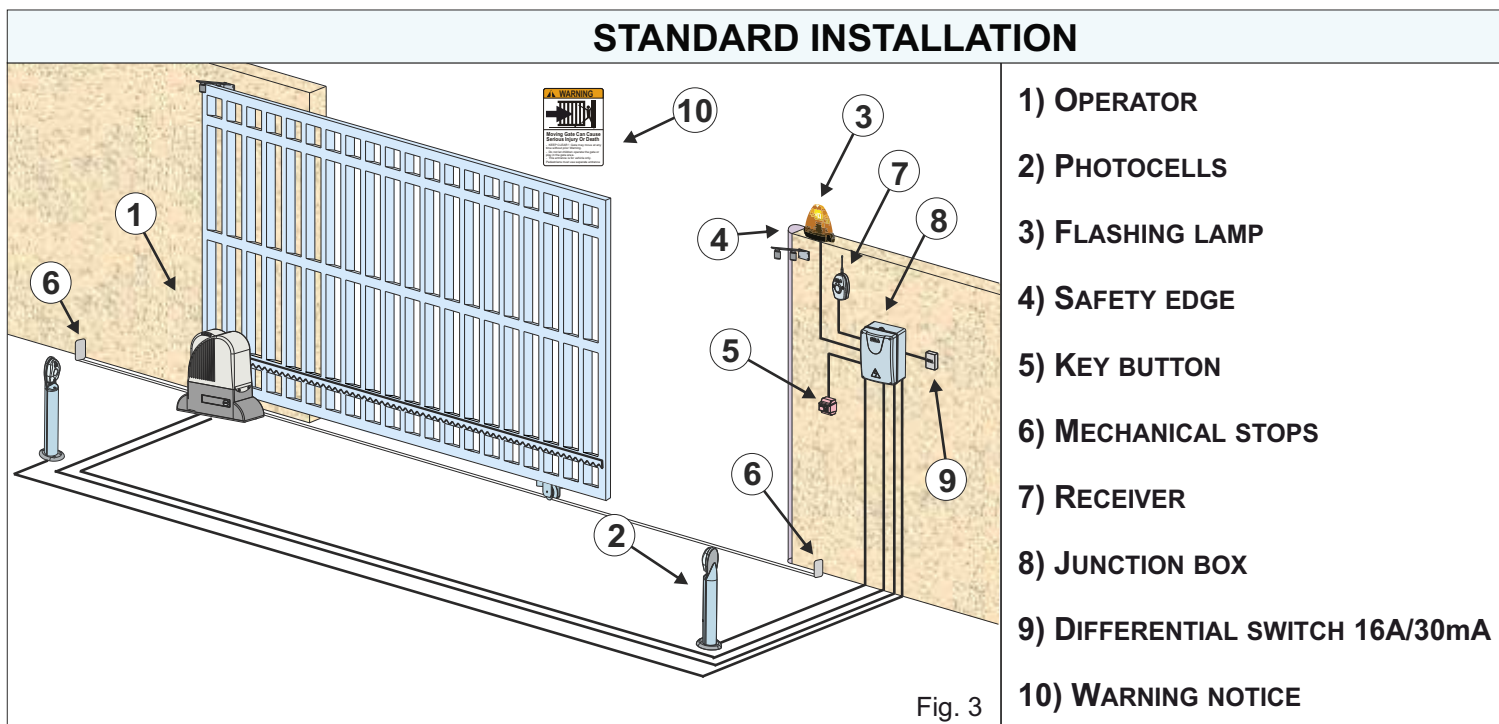

## 1 - GATE ARRANGEMENT

Before the installation, check that all gate parts (fixed and mobile) have a strong and non-deformable structure; also make the following checks:

- a) The gate must be rigid and compact;
- b) The lower gate slideway must be perfectly straight, horizontal and without any obstacles which could obstruct the gate sliding;
- c) The lower sliding wheels must be equipped with greasable or watertightened bearings;
- d) The upper slideway must be perfectly straight and placed so that the gate could be in vertical position;
- e) *The mechanical stops of the gate must always be installed in order to avoid any possible derailment*

## 2 - INSTALLATION OF THE FOUNDATION PLATE

To install the foundation plate it is necessary to:

**2.1.** Prepare a concrete basement according to the dimensions shown in Fig. 4; The foundation plate and the anchor bolts must be concreted inside the basement

***IF ALLOWED BY THE GATE STRUCTURE, IT IS RECOMMENDED TO LIFT THE FOUNDATION PLATE OF ABOUT 50mm FROM THE GROUND, IN ORDER TO AVOID EVENTUAL WATER STAGNATION.***

**2.2.** Before cementing the plate insert a flexible plastic pipe of at least **30 mm** in diameter into the special hole of the plate

**2.3.** Before concreting the plate, make sure that it is perfectly levelled and that the distance of **50 - 55 mm** as shown in Fig. 5 is respected

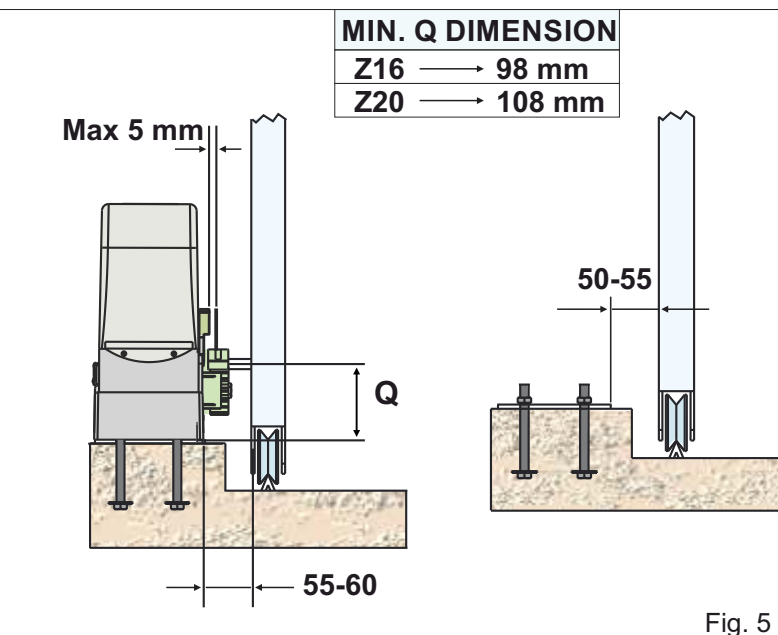
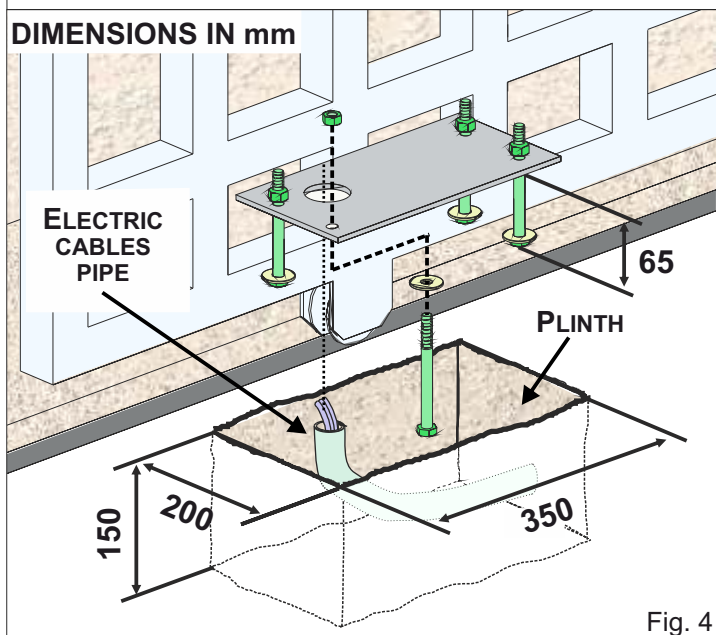

## 3 - PINION MOUNTING

**3.1.** Insert the «A» pin into the gearmotor shaft as shown in Fig. 3a

**3.2.** Mount the pinion and the two seegers on the shaft of the gearmotor as shown in Fig. 6

Fig. 6

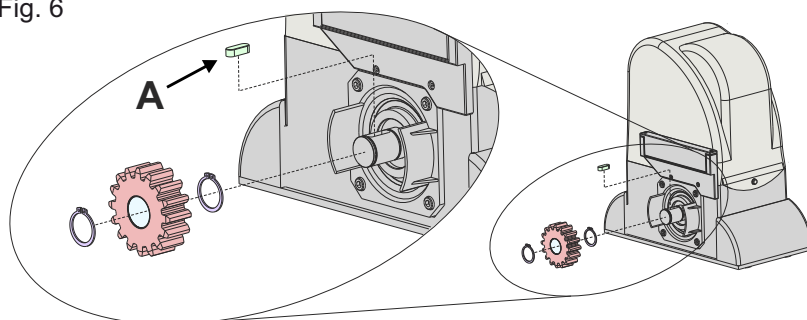

## 4 - INSTALLATION OF THE OPERATOR

4.1. Fix the gearmotor to the foundation plate by the use of the supplied screws - Fig. 7, then adjust its lateral position and height - Fig. 8 - to comply with the dimensions mentioned in Fig. 5

4.2. Insert the two interlocking side covers - Fig. 7



**ATTENTION! REMOVE THE RED TRANSPORT OIL CAP AND REPLACE IT WITH THE BLACK ONE SUPPLIED, PROVIDED WITH AIRHOLE - CHAPTER 9**

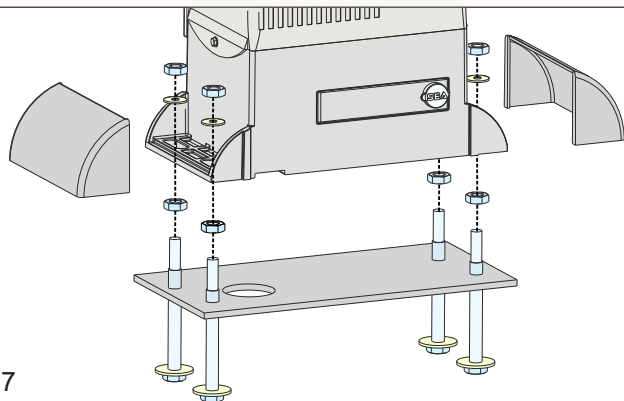

Fig. 7

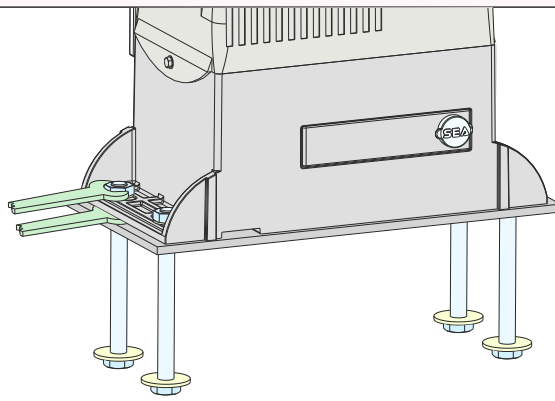

Fig. 8

## 5 - GEAR RACK MOUNTING

5.1. Release the operator and open the gate completely;

5.2. Fix on each gear rack element the support pawls with the appropriate lock screws, making sure to put them in the upper part of the hole - Fig. 9;

5.3. Lean the gear rack element on the toothed pinion of the operator in parallel to the ground slideway of the gate, as shown in Fig. 10 and weld the central pawl **B** to the gate structure - Fig. 11.

Manually move the gate until pawl **C** is placed in front of the pinion and fix it through electric welding. Repeat the same procedure for pawl **A** after having placed it in front of the pinion;

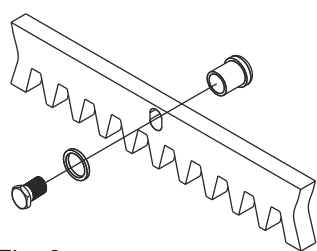

Fig. 9

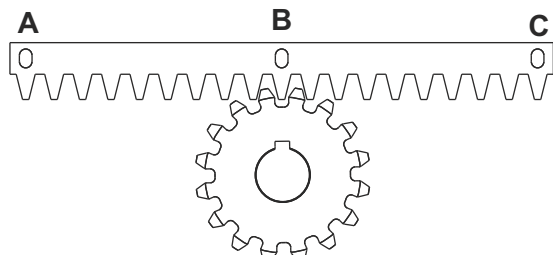

Fig. 10

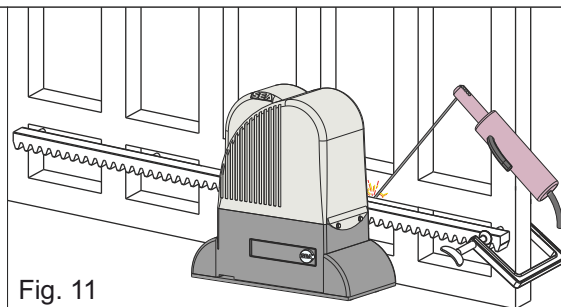

Fig. 11

5.4. Make sure that all the gear rack elements are perfectly aligned and correctly placed (**the teeth must be in phase**). It is suggested to oppose an element to two aligned elements as shown in Fig. 12;

5.5. Repeat the above described operation for all the remaining gear rack elements to be installed;

5.6. To avoid that the gate weights down the pinion - Fig.13 - lift up the whole rack about 1,5 mm.

**Caution! - Keep a gap of about 0,5 mm between pinion tooth and gear rack tooth;**

5.7. Make sure that the gear rack works at the midpoint of the pinion along all the rack elements, if necessary, adjust the length of the spacers

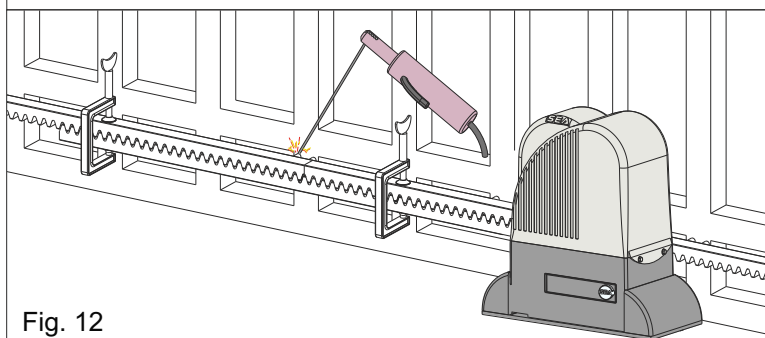

Fig. 12

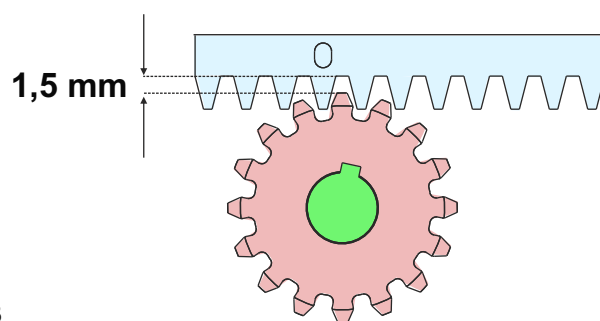

Fig. 13

## 6 - LIMIT SWITCH INSTALLATION ON THE GEAR RACK

### 6.1. IN OPENING

- Fully open the gate

- **MECHANICAL STOP:** place the plate - Fig. 14 - on the rack according to the desired gate stop position; fix the plate on the rack using the screws.

- **INDUCTIVE LIMIT SWITCH:** place the plate - FIG. 15 - on the rack according to the desired gate stop position; fix the plate on the rack using the screws. Bring the inductive limit switch opening plate (indicated by an arrow on the limit switch) in correspondence with point «X» of the plate on the rack (50 mm from the folded side of the plate - Fig. 16).

### 6.2. IN CLOSING

- Fully close the gate

- **MECHANICAL STOP:** place the plate - FIG. 14 - on the rack according to the desired gate stop position; fix the plate on the rack using the screws.

- **INDUCTIVE LIMIT SWITCH:** place the plate - FIG. 15 - on the rack according to the desired gate stop position; fix the plate on the rack using the screws. Bring the inductive limit switch closing plate (indicated by an arrow on the limit switch) in correspondence with point «X» of the plate on the rack (50 mm from the folded side of the plate - Fig. 16).

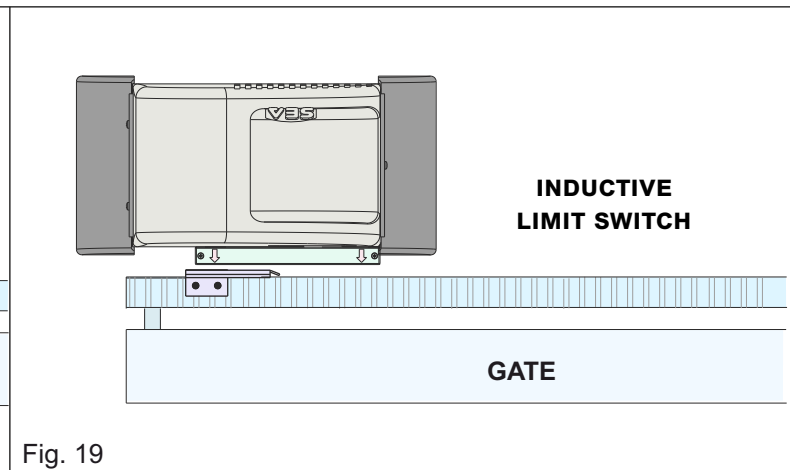
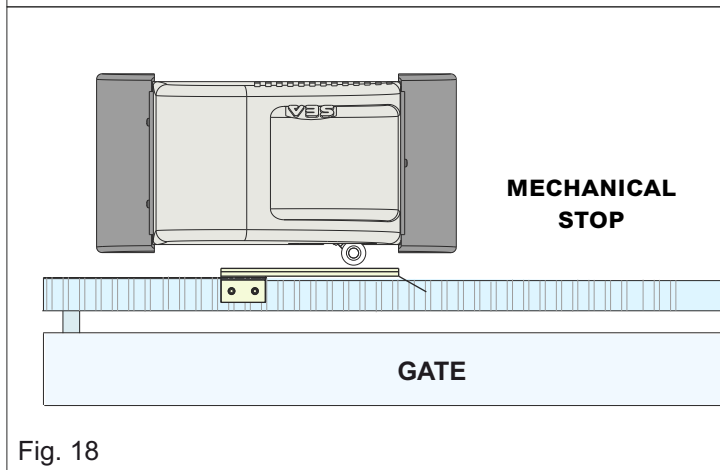
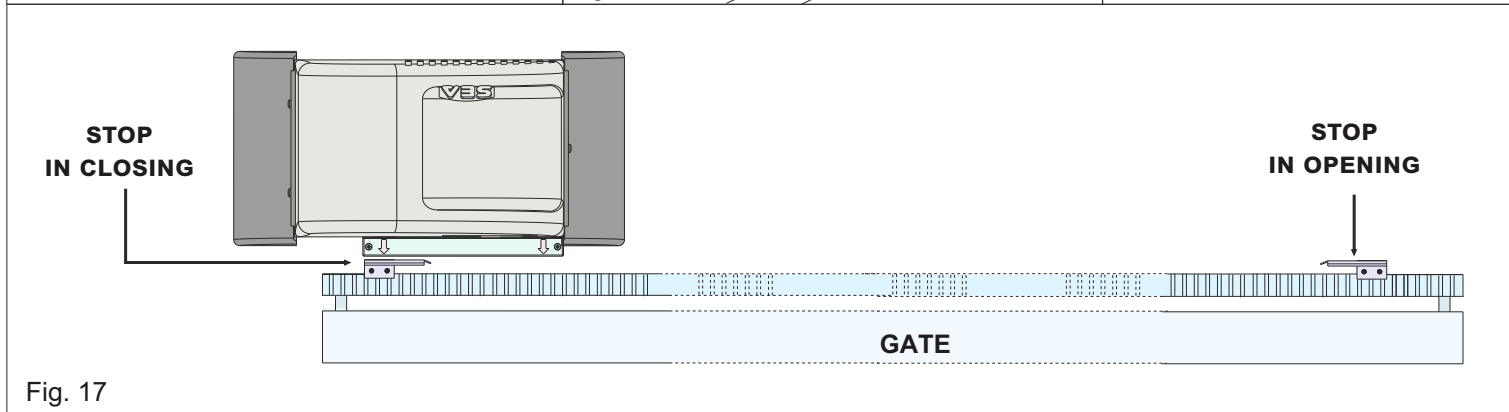
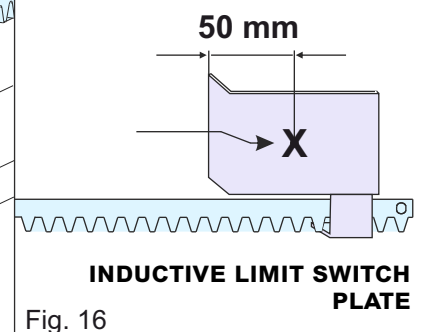
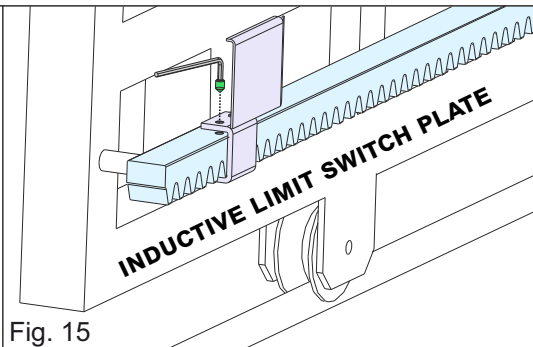
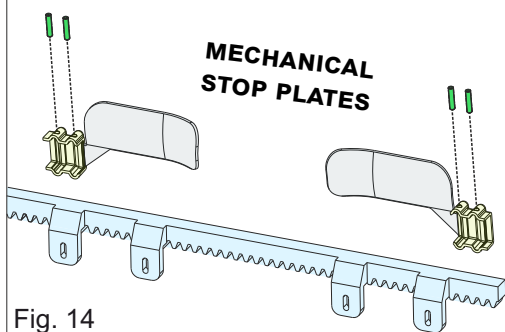

➔ **FOR FURTHER DETAILS ON THE ADJUSTMENT OF THE INDUCTIVE LIMIT SWITCH, REFER TO THE PROGRAMMING MANUAL OF THE ELECTRONIC CONTROL UNIT**

## 7 - INSTALLATION OF THE CHAIN SYSTEM

**7.1.** Secure two sturdy brackets at the two extremities of the gate for attaching the chain - Fig. 20

**7.2.** Install a chain tensioners on each bracket to adjust the chain tension - Fig. 20

**MAKE SURE THAT THE CHAIN TENSIONER AND CHAIN ARE AT A MIN. DISTANCE OF 45 mm FROM THE GATE - Fig. 22**

**7.3. UNLOCK THE OPERATOR USING THE SPECIAL RELEASE KEY - SEE CHAPTER 12**

**7.4.** Install the chain on the chain tensioner at the end of the gate, pass it through the pinion unit, as shown in Fig. 21 and hook it to the chain tensioner on the opposite side. Fig. 23 and Fig. 24 show the correct installation, respectively, with open and closed gate. The chain must always be in line and equidistant from the gate - Fig. 22; if not perfectly aligned - Fig. 25 and Fig. 26, derailments from the pinion unit may occur or the operator could be damaged by excessive overheating due to effort

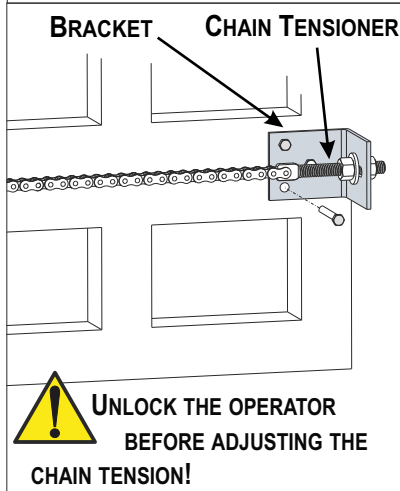

Fig. 20

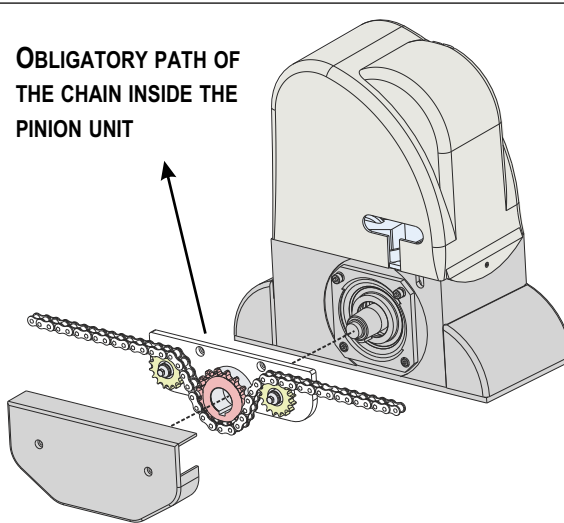

Fig. 21

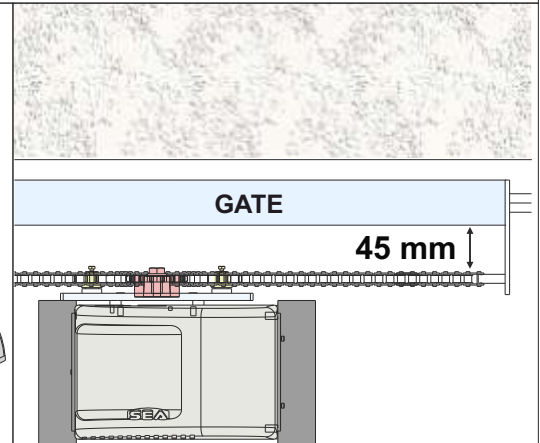

Fig. 22

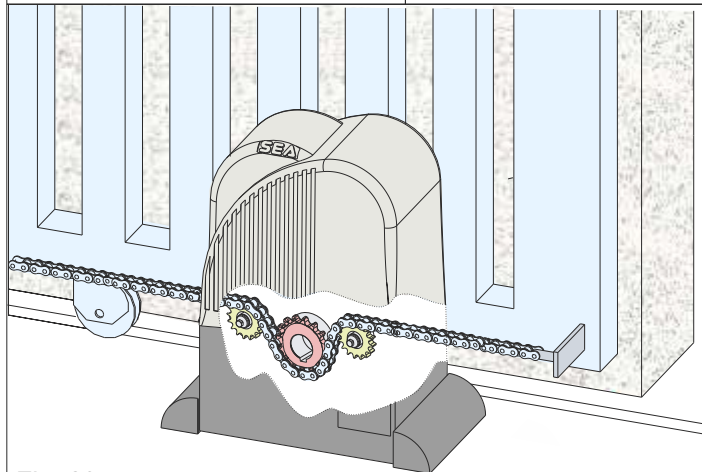

Fig. 23

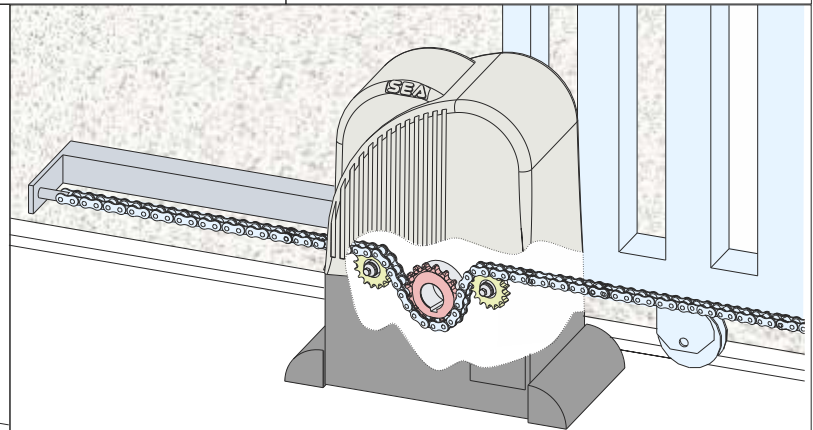

Fig. 24

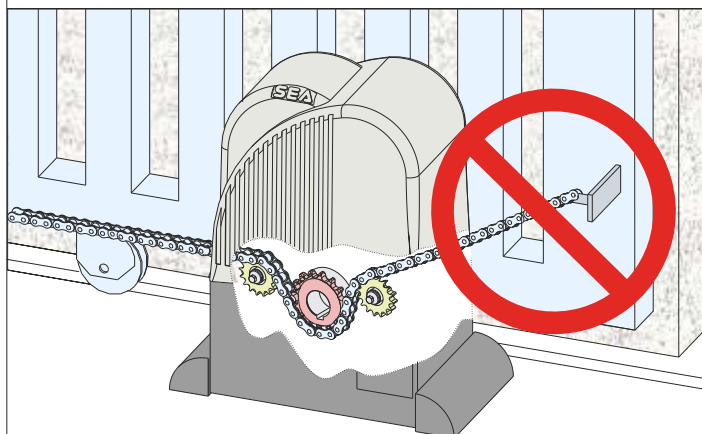

Fig. 25

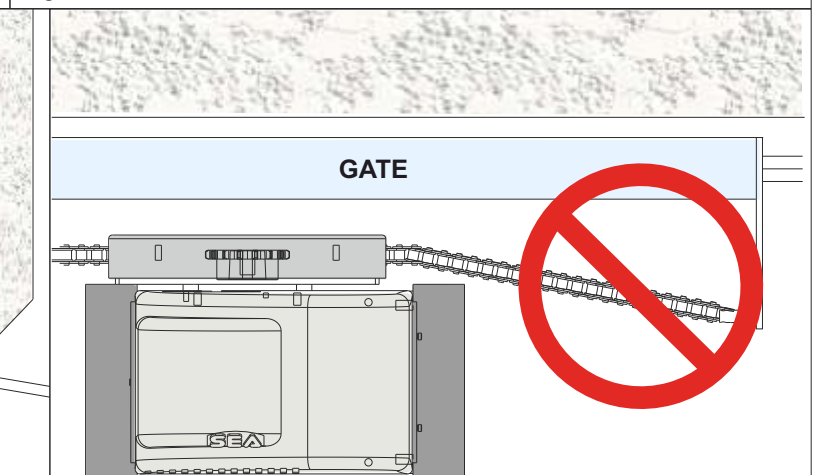

Fig. 26

## 8 - GROUNDING

**8.1.** Before connecting the operator to the power supply, provide for its earthing, by the use of the special earthing screw as shown in Fig. 27

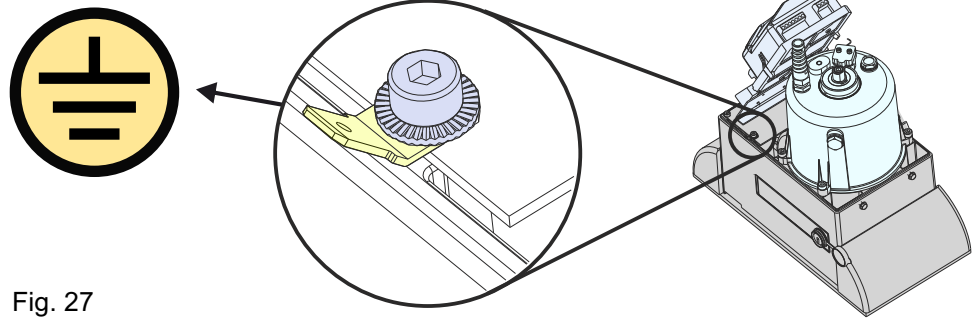

Fig. 27

## 9 - BREATHER CAP REPLACEMENT (OR BREATHER SCREW REPLACEMENT \*)

**9.1.** Before starting the operator, remove the red transport cap (or the transport screw) and replace it with the black cap (or screw) supplied and equipped with the airhole

**\* THE VERSION WITH ELECTRIC BRAKE IS EQUIPPED WITH A BREATHER SCREW**

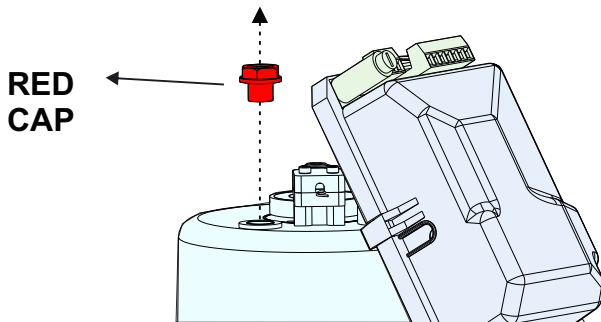

Fig. 28

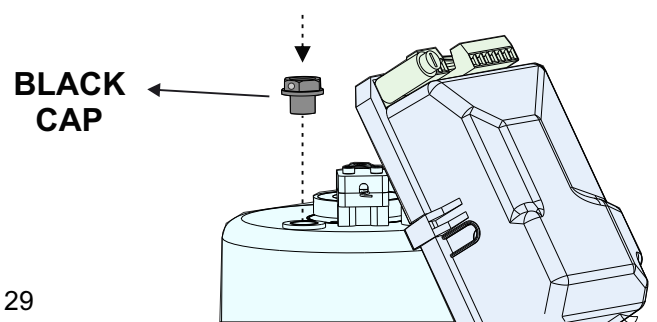

Fig. 29

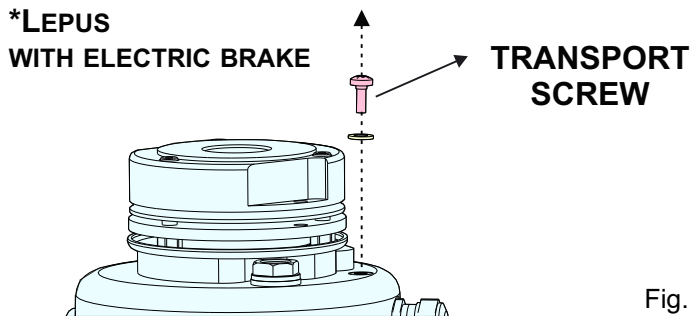

Fig. 30

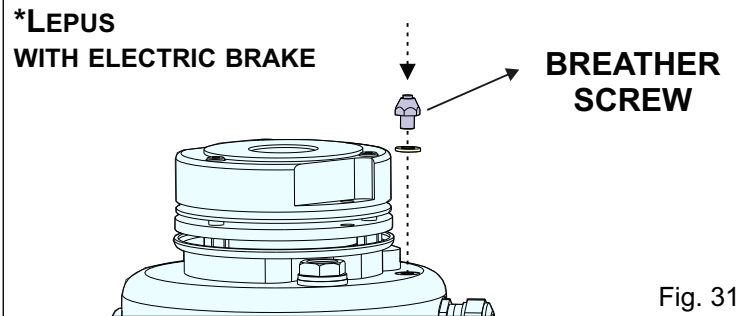

Fig. 31

## 10 - CLUTCH ADJUSTMENT (OPTIONAL)

**10.1.** Switch off the electric power supply

**10.2.** To adjust the clutch, act on the grub screw «A» - Fig. 32 - as follows:

- **CLOCKWISE DIRECTION** = less clutch sensitivity - more thrust force
- **COUNTER-CLOCKWISE DIRECTION** = more clutch sensitivity - less thrust force

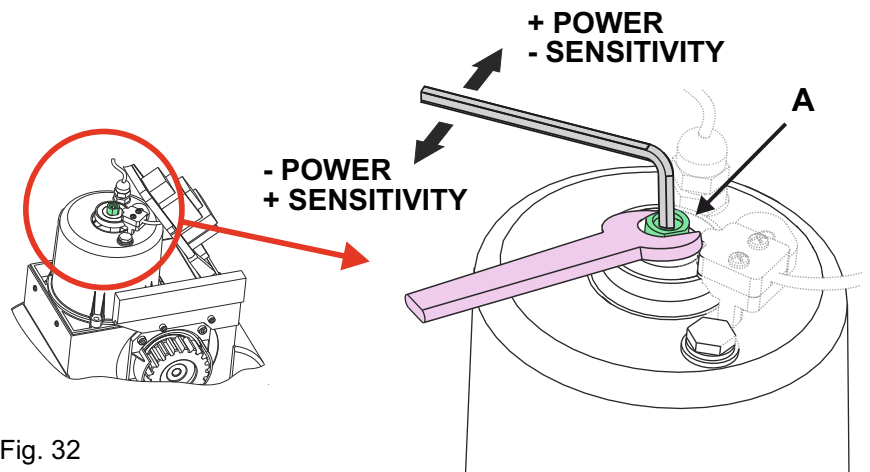

Fig. 32



## 11 - EXTERNAL RELEASE SYSTEM - OPTIONAL

**11.1.** An external release system wired to a safety box can be connected to the LEPUS operator, as shown in Fig. 33

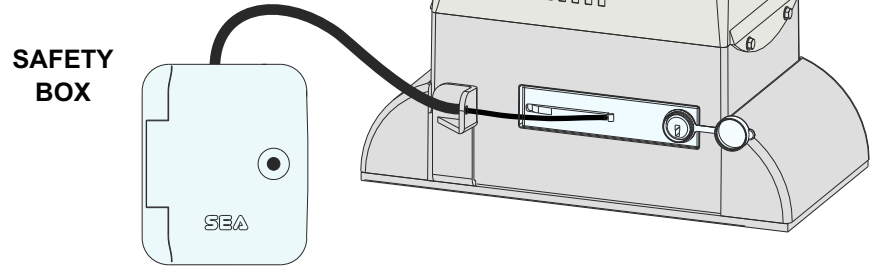

Fig. 33

## PART FOR BOTH INSTALLER AND END-USER



**ALL THE UNLOCKING AND LOCKING OPERATIONS AND ALL PERIODIC MAINTENANCE OPERATIONS MUST BE CARRIED OUT IN ABSENCE OF POWER SUPPLY!**

## 12 - RELEASE SYSTEM

### 12.1. TO RELEASE THE OPERATOR

- Open the lock cover, insert the key and rotate 90° clockwise - Fig. 34
- Pull the release lever until it stops, about 90° - Fig. 35

**when pulling the release lever, the control unit receives a safety stop impulse thanks to a micro-switch inside the operator (anyway, it is highly recommended to switch OFF the power supply before)**

### 12.2. TO LOCK THE OPERATOR

- Push the release lever to the complete closing
- Rotate the key counter-clockwise and extract it
- Close the protective lock cover

**Once the lock has been restored the electronic control unit reactivates - if the power supply was ON!**

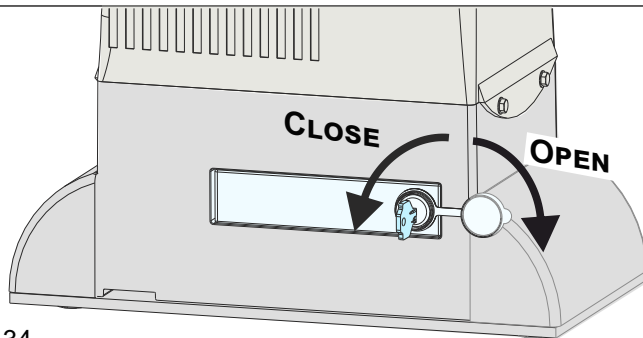

Fig. 34

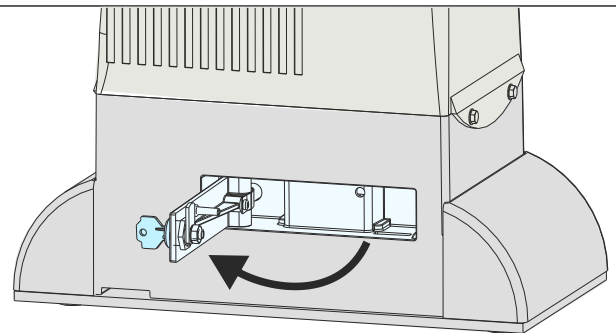

Fig. 35

## 13 - PERIODIC MAINTENANCE - FOR INSTALLERS ONLY!

CHECK THE OIL LEVEL (TRANSPARENT CAP ON THE SIDE OF THE BELL-SHAPED REDUCER)	ANNUAL
CHANGE THE OIL	4 YEARS
CHECK THE CORRECT OPERATION OF THE RELEASE SYSTEM	ANNUAL
CHECK THE CORRECT OPERATION OF THE CLUTCH	ANNUAL
CHECK THE DISTANCE BETWEEN PINION AND GEAR RACK (1.5 mm)	ANNUAL
CHECK THE CONDITION OF THE PINION AND THE GEAR RACK (IF OVERUSED OR DAMAGED)	ANNUAL
CHECK THE FIXING SCREWS	ANNUAL
CHECK THE CONDITION OF THE ELECTRIC CABLES	ANNUAL
CHECK THE OPERATION OF THE LIMIT SWITCHES AND THE CONDITION OF THE STOP PLATES	ANNUAL



**ALL OPERATIONS MUST BE CARRIED OUT EXCLUSIVELY BY AN AUTHORIZED INSTALLER**  
**ALL OPERATIONS MUST BE CARRIED OUT IN ABSENCE OF POWER SUPPLY**

## PART FOR BOTH INSTALLER AND END-USER

### GENERAL NOTICE

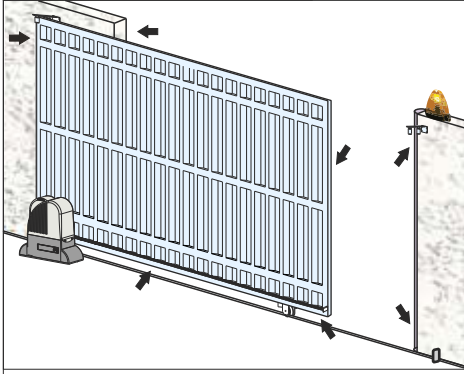

**RISK EXAMINATION:** The points pointed by arrows are potentially dangerous. The installer must take a thorough risk examination to prevent crushing, conveying, cutting, grappling, trapping so as to guarantee a safe installation for people, things and animals (Re. Laws in force in the Country where installation has been made). As for misunderstandings that may arise refer to your area distributor or call our help desk. These instructions are part of the device and must be kept in a well known place. The installer shall follow the provided instructions thoroughly. SEA products must only be used to automate doors, gates and wings. Any initiative taken without SEA explicit authorization will preserve the manufacturer from whatsoever responsibility. The installer shall provide warning notices on not assessable further risks. SEA in its relentless aim to improve the products, is allowed to make

whatsoever adjustment without giving notice. This doesn't oblige SEA to upgrade the past production. SEA can not be deemed responsible for any damage or accident caused by product breaking, being damages or accidents due to a failure to comply with the instructions herein. The guarantee will be void and the manufacturer responsibility will be nullified if SEA original spare parts are not being used. The electrical installation shall be carried out by a professional technician who will release documentation as requested by the laws in force. Packaging materials such as plastic bags, foam polystyrene, nails etc must be kept out of children's reach as dangers may arise.

**INITIAL TEST AND STARTING OF THE AUTOMATION:** After having completed the necessary operations for a correct installation of the product and after having evaluated all the risks which could arise in any installation, **it is necessary to test the automation to guarantee the maximum security and, in particular, to guarantee that the laws in force are fully respected.** The first Start must be executed according to the rule **EN 12445** which establishes the methods of tests for checking the gate automation respecting the limits established by the rule **EN 12453**

**SAFETY PRECAUTIONS:** All electrical work should comply with the current regulations. A 16A / 0,030 differential switch must be used. Separate the source cables (operators, power supply) and command cables (photocells, push-buttons, etc). Be sure the entire system is properly earth bonded. Always run cables in separate ducts to prevent interferences

**INTENDED USE:** The operator has been designed to be used for the automation of sliding gates only

**SPARE PARTS:** Send request for spare parts to: **SEA S.p.A. - Teramo - ITALY - [www.seateam.com](http://www.seateam.com)**

**SAFETY AND ENVIRONMENTAL COMPATIBILITY:** Don't waste product packing materials and/or circuits

**STORAGE:** T = -30°C/+60°C ; Humidity = min. 5% / max. 90% (without condensation); Materials must be properly packaged, handled with care and with appropriate vehicles

**WARRANTY LIMITS** - see the sales conditions

**MAINTENANCE AND DECOMMISSION:** must only be carried out by specialised and authorised personnel

**THE MANUFACTURER CAN NOT BE DEEMED RESPONSIBLE FOR ANY DAMAGE OR INJURY CAUSED BY IMPROPER USE OF THIS PRODUCT**

*SEA S.p.A. reserves the right to make any required modification or change to the products and/or to this manual without any advanced notice obligation.*

1. Read carefully these Instructions before beginning to install the product. Store these instructions for future reference
2. Don't waste product packaging materials and /or circuits
3. This product was designed and built strictly for the use indicated in this documentation. Any other use, not expressly indicated here, could compromise the good condition/operation of the product and/or be a source of danger. SEA S.p.A. declines all liability caused by improper use or different use in respect to the intended one.
4. The mechanical parts must comply with Directives: Machine Regulation 2006/42/CE and following adjustments, Low Tension (2006/95/CE), Electromagnetic Consistency (2004/108/CE); Installation must respect Directives: EN12453 and EN12445.
5. Do not install the equipment in an explosive atmosphere.
6. SEA is not responsible for failure to observe Good Techniques in the construction of the locking elements to motorize or for any deformation that may occur during the use
7. Before attempting any job on the system, cut out electrical power and disconnect the batteries. Be sure that the earthing system is perfectly constructed, and connect to it the metal parts of the gate
8. Use of the indicator-light is recommended for every system, as well as a warning sign well-fixed to the frame structure.
9. SEA declines all liability concerning the automated system safety and efficiency, if components used are not produced by SEA
10. For maintenance, strictly use original parts by SEA.
11. Do not modify in any way the components of the automated system.
12. The installer shall supply all information concerning the system manual functioning in case of emergency and shall hand over to the user the warnings handbook supplied with the product.
13. Do not allow children or adults to stay near the product while it is operating. The application cannot be used by children, by people with reduced physical, mental or sensorial capacity or by people without experience or necessary training. Keep remote controls or other pulse generators away from children, to prevent involuntary activation of the system.
14. Transit through the leaves is allowed only when the gate is fully open.
15. The User must not attempt to repair or to take direct action on the system and must solely contact qualified SEA personnel or SEA service centers. The User can apply only the manual function of emergency.
16. The power cables maximum length between the central engine and motors should not be greater than 10 m. Use cables with 2,5 mm<sup>2</sup> section. Use double insulation cable (cable sheath) to the immediate vicinity of the terminals, in particular for the 230V cable. Keep an adequate distance (at least 2.5 mm in air), between the conductors in low voltage (230V) and the conductors in low voltage safety (SELV) or use an appropriate sheath that provides extra insulation having a thickness of 1 mm

# DECLARATION OF CONFORMITY

## DICHIARAZIONE DI CONFORMITÀ

SEA S.p.A. declares under its proper responsibility and, if applicable, under the responsibility of its authorised representative that, by installing the appropriate safety equipment and noise filtering, the products:

*La SEA S.p.A. dichiara sotto la propria responsabilità e, se applicabile, del suo rappresentante autorizzato che, con l'installazione degli adeguati dispositivi di sicurezza e di filtraggio disturbi, i prodotti:*

DESCRIPTION - DESCRIZIONE	MODEL - MODELLO	TRADEMARK - MARCA
LEPUS 600 (AND ALL ITS BY-PRODUCTS - E TUTTI I SUOI DERIVATI)	11102025	SEA
LEPUS 1600 (AND ALL ITS BY-PRODUCTS - E TUTTI I SUOI DERIVATI)	11110300	SEA
LEPUS 2000 THREEPHASE - TRIFASE (AND ALL ITS BY-PRODUCTS - E TUTTI I SUOI DERIVATI)	11110500	SEA

- are built to be integrated into a machine or to be assembled with other machinery to create a machine under the provisions of Directive 2006/42/CE;

- comply with the essential safety requirements related to the products within the field of applicability of the Community Directives 2014/35/UE and 2014/30/UE

*- sono costruiti per essere incorporati in una macchina o per essere assemblati con altri macchinari per costruire una macchina ai sensi della Direttiva 2006/42/CE;*

*- sono conformi ai requisiti essenziali di sicurezza relativi ai prodotti entro il campo di applicabilità delle Direttive Comunitarie 2014/35/UE e 2014/30/UE*

THE MANUFACTURER OR THE AUTHORIZED REPRESENTATIVE  
IL COSTRUTTORE o IL RAPPRESENTATE AUTORIZZATO

PLACE AND DATE OF ISSUE  
LUOGO E DATA DI EMISSIONE

TERAMO, 06/09/2022

SEA S.p.A.  
ZONA INDUSTRIALE SANT'ATTO  
64100 - TERAMO - ITALY  
+ 39 0 861 588341  
[www.seateam.com](http://www.seateam.com)

L'Administratore  
The Administrator  
Ennio Di Saverio





**SEA**®



**Automatic Gate Openers**

International registered trademark n. 804888

**SEA S.p.A.**

**Zona Industriale Sant'Atto - 64100 - Teramo - ITALY**

**Tel. +39 0 861 588341 r.a. Fax +39 0 861 588344**

**[www.seateam.com](http://www.seateam.com)**